

Detection of Actuator Faults for an Attitude Control System using Neural Network

S. Montenegro and W. Hu

Abstract—The objective of this paper is to develop a neural network-based residual generator to detect the fault in the actuators for a specific communication satellite in its attitude control system (ACS). First, a dynamic multilayer perceptron network with dynamic neurons is used, those neurons correspond a second order linear Infinite Impulse Response (IIR) filter and a nonlinear activation function with adjustable parameters. Second, the parameters from the network are adjusted to minimize a performance index specified by the output estimated error, with the given input-output data collected from the specific ACS. Then, the proposed dynamic neural network is trained and applied for detecting the faults injected to the wheel, which is the main actuator in the normal mode for the communication satellite. Then the performance and capabilities of the proposed network were tested and compared with a conventional model-based observer residual, showing the differences between these two methods, and indicating the benefit of the proposed algorithm to know the real status of the momentum wheel. Finally, the application of the methods in a satellite ground station is discussed.

Keywords—Satellite, Attitude Control, Momentum Wheel, Neural Network, Fault Detection.

I. INTRODUCTION

SINCE several years ago, the influence of automation on the operation and the design of technical processes increased progressively. This development of expanding process automation was caused by an increasing demand on the process performance or the product quality, the independence of process operation from the presence of human operators, relieve of operators from monotonic task and because of rising wages. [1].

As the satellites are very important for improve almost everything in the life, then the process of automation had been helping the progress in this qualified field. Usually, the researchers are attempting to do some hardware and software in order to upgrade the system, but sometimes they have some limitations due to the equipment's performances. The variables' control is a goal during the designing and development for the system, this course of action is not easy, afterward is necessary to use the fault detection, diagnosis and Isolation.

The appeal of neural networks and its application to fault diagnosis that has been studied in [4], [5], [6], [14], [15] are

S. Montenegro is PhD Candidate, School of Astronautics, Beihang University 100191. Beijing, China (Phone: 0086-134-66724763; fax: 0086-10-82057910; e-mail: salomon93@gmail.com).

W. Hu is professor from School of Astronautics, Beihang University 100191. Beijing, China (e-mail: weiduo.hu@gmail.com).

due to their capabilities to cope with nonlinearity, complexity, uncertainty, noisy and corrupted data. Neural networks constitute suitable modeling tools for represents highly nonlinear processes. Generally, it is more advantageous to develop a nonlinear neural network based model for a range of operating conditions than to develop a bank of linear models, each developed for a particular operating point, therefore rendering neural networks as ideal tools for generating residuals. [7].

Fault diagnosis and identification had been widely researched during the recent years due to the increasing demand on reliable operation of safety critical control systems, such as intelligent vehicles and future planned autonomous spacecraft/probes. The main task for fault diagnosis schemes are to detect and isolate occurring faults in order to avoid overall failure of the monitored system and any catastrophes involving human fatalities and material damage. [2].

Satellite communications links add capacity to existing communications capabilities and provide additional alternate routings for communications traffic. Satellite links, as one of several kinds of long-distance links, interconnects switching centers located strategically around the world [3]. Regarding the communication satellite and the attitude, both have a relationship, which represents an interesting point for this paper, because the actuator's performance allow maintaining the desired antenna pointing, for that reason if it is working properly without any fault the results for the satellite's users will be the best.

There are lot researches going to avoid the actuator's fault and they are using different methods in order to do it, one of them is represent by the neural network, where are used and combined with other variables, with the main objective of procure the best performance for the system. Following these researchers we present this paper attempting to develop a neural network based fault detection and isolation scheme (FDI) for the Attitude Control Subsystem (ACS) of a satellite. Due to the necessity for an efficient tools that can allow more autonomy, with minimal support from the ground station and operators detect and isolate faults in the spacecraft that is estimated to work under unforeseen conditions, significant uncertainties, and disturbances in outer space; in this paper we will develop a diagnosis algorithm for the momentum wheel (MW) that is commonly used as an actuator in the ACS of these systems.

This paper is organized as follows. Initially and introduction regarding the area, and then a neural network structure is commented in part II, after that it is applied to the momentum

wheel dynamic model in the next section, then some faulty scenarios and the respective results for the application of our proposed neural network are presented in the part IV. With the aim of demonstrate and illustrate the capabilities of our proposed fault detection approach, a comparative evaluation of the results is performed using benchmark a linear model-based observer residual generator and finally the conclusions.

II. NEURAL NETWORK

In section II, we are going to develop a neural network observer-based scheme for fault detection and isolation in momentum wheels. The neural FDI scheme will be employed to perform the detection and isolation tasks of the diagnosis system using different neural network structures.

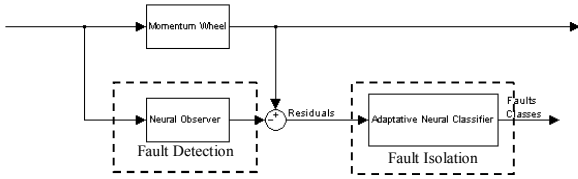

Fig. 1 General Structure of the neural network FDI Scheme

In mathematical model-based fault diagnosis schemes, a model for the plant is built first. Then diagnostic residuals are generating through comparing the output of the practical system with the output of the model. Next, the residuals are used to diagnose faults [11], [14]. An important assumption for the model-based fault diagnosis schemes is that the mathematical models are able to represent the practical systems with sufficient accuracy. Otherwise, the mismatch between the practical systems and their models as well as disturbances might cause the proposed fault diagnosis schemes unreliable.

In this section a generalized structure of dynamic neuron model is introduced, which was proposed in [12] considered in [14] and here. The structure of the dynamic neural network is a generalization of the conventional static model accomplished by adding an Infinite Impulse Response (IIR) filter to neuron transfer function.

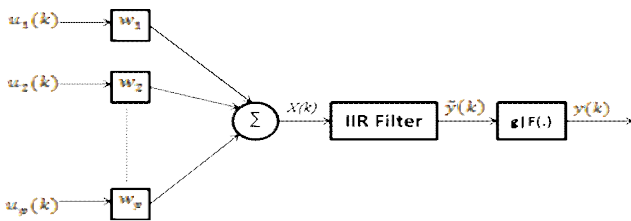

Fig. 2 Dynamic Neural Network with P inputs

There are three main operations are performed in this dynamic neuron structure, beginning with the weighted sum of the inputs which is calculated according the following expression [5]:

$$x(k) = w^t u(k) = \sum_{p=1}^P w_p u_p(k) \tag{1}$$

Where $w=[w_1 w_2 w_3...w_p]$ denotes the input-weight vector, P is the number of inputs and $u(k)=[u_1(k).u_2(k)...u_p]^T$ is the input vector. Hence, the computed weighted sum of the inputs $x(k)$ is passed through the IIR filter. The corresponding characteristics of the filter can be described by the following difference equation:

$$\tilde{y}(k) = \sum_{i=1}^n b_i x(k-i) - \sum_{i=1}^n a_i \tilde{y}(k-i) \tag{2}$$

Since represents the filter input, $\tilde{y}(k)$ denotes the filter output, $a=[a_1 a_2 a_3...a_n]$ and $b=[b_0 b_1 ...b_n]$ are the feedback and feed-forward paths weighted by the vector weight, and n denotes the filter order. The neuron output can be formulated as:

$$y(k) = F(g \cdot \tilde{y}(k)) \tag{3}$$

Where $F(\cdot)$ is the nonlinear activation function that produces the neuron output $y(k)$ and g is the parameter of the activation function defining its slope.

Owing to the neuron's internal dynamic system properties the DMLP processes the modeled system measurements at the current time instant k thereby reducing the input space of trained network in comparison with Elman and another recurrent DML network [13].

The network has to be trained for accomplish the task of replacing the analytical model that describes the MW in normal mode of operation. Learning data is collected directly from the simulation model of the MW developed by [10] that is as realistic as possible. After the training process, the dynamic neural network is ready for on-line residual generation. The proposed dynamic neural network can has equal structure as a standard feed forward backpropagation network. The calculated output error is propagated back to the input layer through the hidden layers containing dynamics filters, where the extended dynamic backpropagation algorithm can be defined and it can operate in both modes of training, on or off-line [13].

III. MOMENTUM WHEEL MODEL

The attitude of a spacecraft is its orientation in space, it depend upon control subsystem who allows stabilize and reorient the spacecraft, this paper is concerned with some aspects of spacecraft attitude; in order to know how to control them and determine when there are various faults, and then the MW represents an important device in this field, due to the functioning during the spam life of the satellite. Belonging to the subsystem, this stabilizes the S/C and reorients it in desired direction despite the external disturbance torques acting on the satellite.

Momentum Wheel is a flywheel designed to operate at biased, or nonzero, momentum. It provides variable-momentum storage capability about its rotation axis, which is

usually fixed in the vehicle [8], [9], [14]. This device is used primarily to provide the spacecraft with the momentum bias necessary for inertial attitude stability. As a byproduct, the momentum wheel can also develop torque for controlling the attitude of the satellite's axis that is parallel to the momentum wheel's axis rotation [9]. MW is used for spacecraft attitude control and consists of a heavy rotating disk or wheel. Even though the momentum wheels are very accurately balanced statically and dynamically, the high speed of operation (≈ 4500 to 5400 RPM), causes dynamic disturbances to the spacecraft; of course, reality is not so simple, this device has an electrical motor which provides according the input voltage and the himself electrical resistance (R_M) control the torque desired.

According [9] the basic equation that converts an electrical motor into what is known as a momentum wheel (MW) is:

$$\frac{\dot{h}_w}{T_c} = \frac{1}{1 + s\left(\frac{R_M}{K}\right)} \quad (4)$$

The above equation gives a linear model for the momentum exchange device. Technically, such a device has a torque and velocity limitations; when the attitude control of a satellite is designed, these limitations must be taken into consideration.

The MW is in essence a momentum transfer and storage device which provides torque to the vehicle and store angular momentum. It consist of a rotating flywheel that is driven by an internal brushless DC motor, the use provides usefulness for the attitude control. Based on MATLAB Simulink blocks a detailed block diagram of the momentum wheel is an adaption support on the reaction wheel model developed by [10] is shown in Fig. 3.

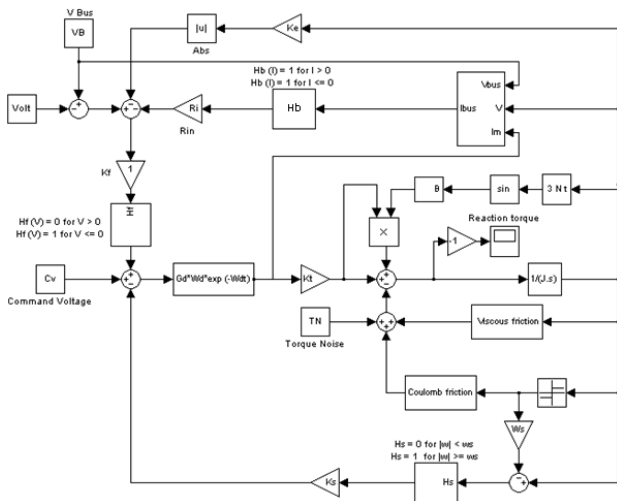

Fig. 3 Block Diagram of Momentum Wheel

The above schematic of the momentum wheel allows us to obtain a relationship in the ACS of the satellite to be used for a high fidelity mathematical model. It must be emphasized that this block regard the mathematical description will be used for the simulations, introducing any faults in order to check the neural network time responding. Typical parameters for the

MW are coming from the T-SAT virtual satellite developed by [3] and are shown in details in [10]. The above MW model developed is subsequently used for diagnosis in the ACS system including the nonlinear attitude dynamics model of the satellite, also the model will be modified in order to include fault injection capabilities which will be shown later.

The configuration in a typical three-axis stabilized communication spacecraft, two-momentum wheels and one reaction wheel are used for attitude control [9]. One geostationary virtual spacecraft developed by [3] represents an example for this configuration, where two momentum wheels (MW) are attached to the spacecraft structure using brackets. This satellite was developed accomplishing some special requirements, like attitude error of normal mode, which must be less than: Roll: $\pm 0.05^\circ$, Pitch: $\pm 0.05^\circ$ and Yaw: ± 0.15 , also during normal mode, Satellite has the ability to do W/E station-keeping.

The satellite needed to meet the ACS accuracy requirements (in our case, the satellite should be maintained within the range of a Earth-pointing attitude in all the three axes for any attitude set point change in a specified range) in order to guarantee the reliability of the system and so on.

IV. SIMULATIONS RESULTS

A. System Identification

The modeled Momentum wheel at the pitch axis has one input (Torque Command Voltage) and one output which is the reaction torque and is simulated in order to generate input and output training data to be used for training purposes. The training process for the dynamic network was carried out using an extended dynamic backpropagation algorithm for about 10,000 time samples (msec). Preprocessing steps are performed for the network inputs and targets so that all the input-output data vectors are normalized.

During the training process the dynamic network allows us to know the real status, according the results and then we can said that after the 15,000 times samples (msec), the network is well trained, because during the training phase (depicted in fig. 4), the performance was really good getting the best result with the network structure N_{1-13-1} (one input, 13 neurons in the hidden layer and one neuron in the output layer), this structure was chosen after several tests in order to get the best one for our system.

In order to check the capability of the trained network, the DNN is evaluated through generalizing it with another data set of 15,000 samples (Fig. 5) that was not seen previously by the network, then after that we got some results regarding this evaluation which are indicating that the output of the neural network follows the actual model's output, and that situation allows us to notice that the neural model is capable for detecting any changes in the reaction wheel input signal (i.e. command voltage). Also, we can notice that the difference between the momentum wheel model and the neural model is due to the error between the actual and the estimated reaction torque signal when the noise is present.

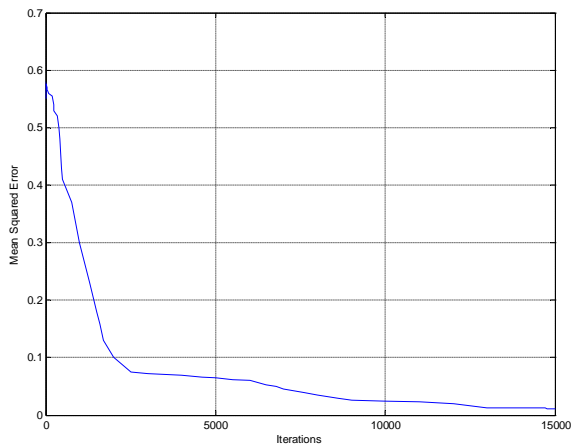

Fig. 4 Training Phase for the Dynamic Neural Network

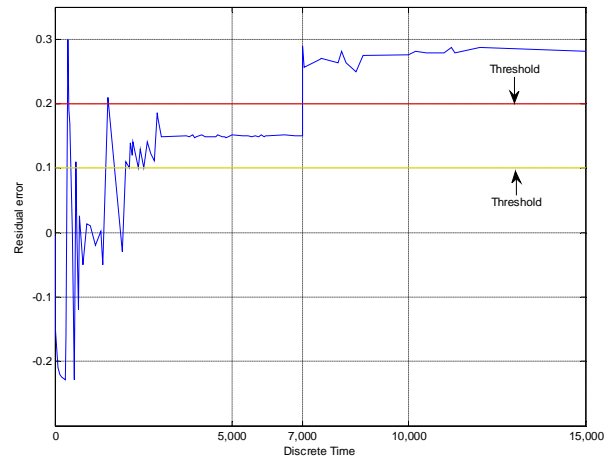

Fig. 6 Residual error from the dynamic neural network, the over bus fault.

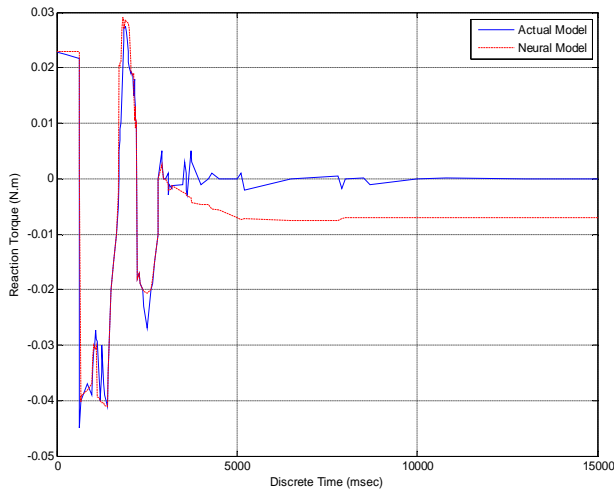

Fig. 5 DNN Testing phase (msec)

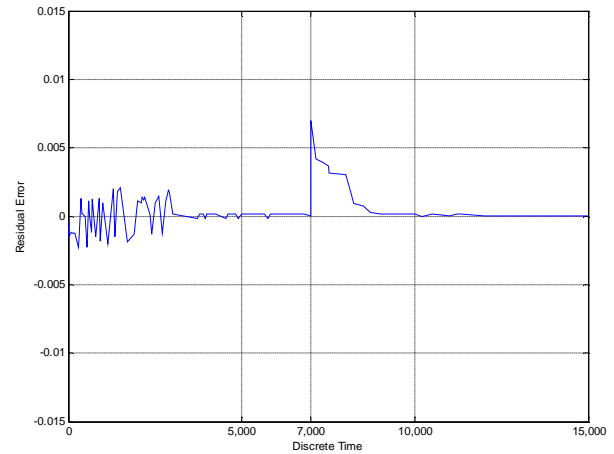

Fig. 7 Residual error from the linear model-based observer, the over bus fault.

B. Fault Detection

The created residual generator is applied regarding the fault detection in the satellite's actuator, specifically at the momentum wheel of communication satellite, and then different types of faults are considered allowing to us to generate fault scenarios under noisy working conditions, which are used and have been injected to the close loop attitude controlled system. Bellow is presented the simulation results in order to shown the dynamic neural network behavior under different conditions.

Case 1: Bus Voltage Fault

Regarding the low bus voltage conditions, it is important to know that the motor torque may be limited at high speeds due to the increasing back-EMF, K_e , of the motor. From a disturbance standpoint, it should also be noted that the available motor torque will at that point be coupled directly to the bus voltage, and any fluctuations in bus voltage will be sensed as torque disturbance [10]. Initially, an over bus voltage faulty scenario was injected at the time sample 7,000 msec, as shown in Fig. 7. The fault diagnosis is principally performed during the steady state response of the satellite which is reached after approximately the 4,000 msec samples, and all the other simulation results that are shown after this state. The result in this figure allows knowing how the proposed dynamic neural network residual generator is capable of recognizing and determining the presence of a fault that is very close to the time that the actual fault has occurred.

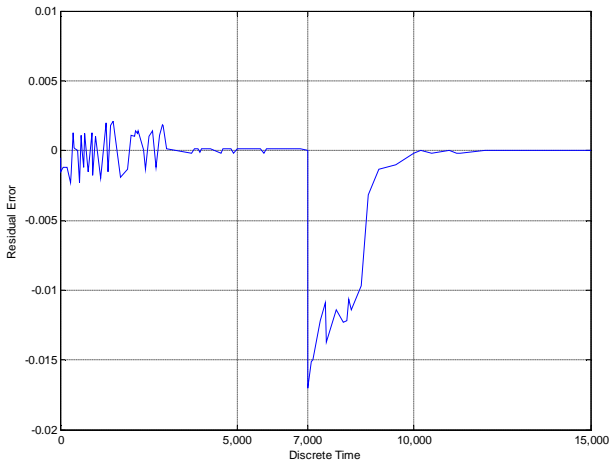

Fig. 8 Residual error generated from the linear residual, low bus fault.

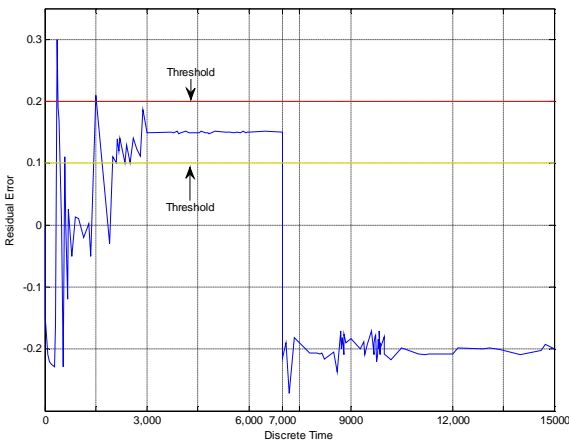

Fig. 9 Residual error generated from the Dynamic Neural Network when the low bus fault occurs.

Now, in order to compare our result above with a model-based linear residual generator design, which we treated as a benchmark fault detection strategy, was developed and implemented. The result is exposing in Fig. 7 which shows that designed observer is not capable for to detect the presence of the fault. It is clearly seen that although the fault has persisted in the MW, the residual generated by the model-based approach has converged back to its normal condition. The process for making fault detection decisions can be accomplished by using a simple threshold in the interval [0.1, 0.2], so that any deviation from this range will be considered as a fault. This threshold was selected after performing a number of simulations under different operating conditions to guarantee that our proposed approach will work successfully with minimal false alarms. To demonstrate this further, successful fault detection is also obtained when a low bus voltage fault scenario, which is simulated in Fig. 7, is applied to the MW. For comparison, the model-based observer

residual output is also depicted in Fig. 8 for the same faulty situation. It follows clearly that the linear residual generator again could not detect unambiguously the faulty situation.

In order to do the fault detection decisions, this process can be accomplished by using a simple threshold in the interval [0.1, 0.2], so that any deviation from this range will be considered as a fault. This threshold was selected after performing lot simulations under different operating conditions to guarantee that our proposed approach will work successfully with minimal false alarms. To demonstrate this further, successful fault detection is also obtained when a low bus voltage fault scenario occurs, which is simulated in Fig. 8, is applied to the MW. For comparison, the model-based observer residual output is also depicted in Fig. 9 for the same faulty situation. It follows clearly that the linear residual generator again could not detect unambiguously the faulty situation, while our proposed Dynamic Neural Network can to detect the fault.

Case 2: Motor Driver Gain Fault.

As was mentioned before, another scenario is presented, introducing a fault at 7000 msec. In this case, the motor control torque block (K_t), which is shown in fig. 3, consists of a voltage controlled current source with gain G_d and a motor with torque constant. The main function of this block is to generate a motor current that is proportional to the torque command voltage and to convert this current into torque through the motor torque constant K_t . Therefore, any injected fault in the motor driver gain will be reflected directly as fluctuations in the motor current and as result in the motor torque. A defective scenario is presented to the motor driver so that an over current faulty situation is obtained. The capabilities of our proposed dynamic network residual generator and a model-based linear observer in detecting this kind of fault are depicted in Figs. 10 and 11, respectively.

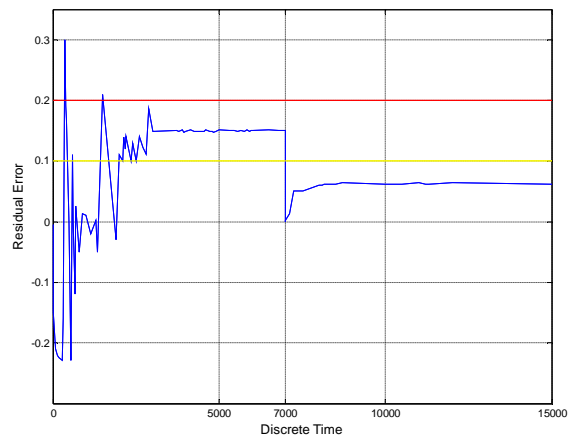

Fig. 10 Residual error generated from the dynamic neural network after the motor driven gain fault.

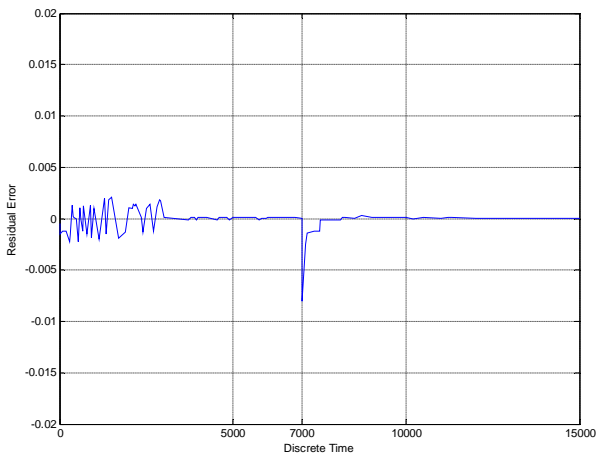

Fig. 11 Residual error generated from the linear observer after the motor driven gain fault.

We can notice the plots in the figures, which shown clearly that the neural network approach is capable to detect the injected fault, while the residual generator had a very poor performance.

Case 3 Doble Fault Scenario

Again a fault is injected, but this time is double, we mean in the bus voltage and motor driver gain successively. Over the bus voltage fault was injected at 7000 msec and after that is injected another one, but at 10000 msec in the motor driven gain.

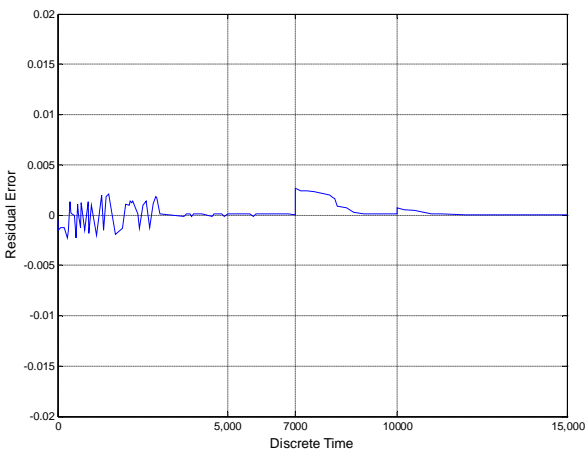

Fig. 12 Residual error generated from the linear observer after the double fault.

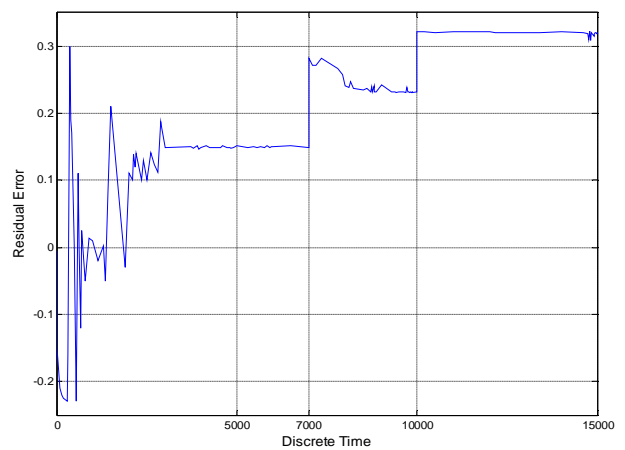

Fig. 13 Residual error generated from the dynamic neural network after the double fault.

The dynamic neural network, as is demonstrated in Fig. 13, detects the injected double faults rapidly. This indicates that the predicted output of the dynamic neural network clearly deviates from the output of the actual system, while in Fig. 12 we can to check that the linear residual generator observer has failed completely in detecting the severe double faults.

V. CONCLUSIONS

Our dynamic neural network residual generator is constructed based on the Dynamic Multilayer Perceptron Network. A generalized embedded structure for the dynamic neuron model is considered in the DMLP network. The developed fault detection and diagnosis technique is applied to a momentum wheel model that is normally used as an important actuator in the ACS of a satellite. From the simulation results shown it can be concluded that the dynamic neural residual generator has produced a very reliable performance in detecting both a single and double faults that have been injected into the wheel system.

Comparisons with a linear model-based observer acting as a residual generator are also included to demonstrate the capabilities and advantages of the proposed dynamic neural network scheme. We have shown that the performance of the linear residual generator was very bad and wasn't capable to determine when the faults were injected, then this paper shown the improvement in fault detection with a dynamic neural network-based approach, allowing to the ground station save more time and faster responses than another used methods.

REFERENCES

- [1] R. Isermann "Fault-Diagnosis System," Springer-Verlag Berlin Heidelberg, 2006.
- [2] R. Patton, F Uppal and C. Lopez-Toribio, "Soft computing approaches to fault diagnosis for dynamic systems: a survey," 4th. IFAC Symposium on fault Detection Supervision and Safety for technical processes, Budapest, Vol. 1, pp. 298-311, June 2000.
- [3] S. Montenegro and K. Amezcua, "Accomplishing Station Keeping Mode for AOCS designed for T-SAT," Advances in Neural Network

- Research, The sixth ISSN 2009, Wuhan, China, pp. 507-516. Springer-Verlag, 2009.
- [4] A. Alessandri, "Fault diagnosis for nonlinear systems using a bank of neural estimators," *Computers in Industry*, Vol. 52, No. 3, pp. 271 - 289, Dec. 2003.
- [5] K. Patan, T. Parisini, "Identification of neural dynamic models for fault detection and isolation: the case of a real sugar evaporation process" *Journal of Process Control*, Vol. 15, No. 1, pp. 67 - 79, 2004.
- [6] T. Sorsa, H. N. Koivo, and H. Koivisto, "Neural networks in process fault diagnostics," *IEEE Transactions on Systems, Man, and Cybernetics*, Vol. 21, No.4, 815 - 825, 1991.
- [7] S. Simani, C. Fantuzzi and R. J. Patton, "Model-Based Fault Diagnosis in Dynamic Systems Using Identification Techniques," Springer 2003
- [8] J. Wertz. "Spacecraft Attitude Determination and Control." Kluwer Academic Publishers, 1978.
- [9] M. J. Sidi. "Spacecraft Dynamics and Control." Cambridge University Press, Cambridge New York, 1997
- [10] B Bialke, "High fidelity mathematical modelling of reaction wheel performance," 21st Annual American Astronautical Society Guidance and Control Conference, pp. 483-486, Feb. 1998.
- [11] W. Qing and S. Mehrdad "Model-based Robust Fault Diagnosis for Satellite Control Systems Using Learning and Sliding Mode Approaches," *Journal of Computers*, Vol. 4, No. 10, Simon Fraser University, Vancouver, BC, Canada. 2009.
- [12] M. Ayoubi, "Fault diagnosis with dynamic neural structure and application to a turbo-charger," *Proc. Int. Symp. Fault Detection Supervision and Safety for Technical Processes, AFEPROCESS'94*, Espoo, Finland, Vol. 2, pp. 618 - 623, 1994.
- [13] J. Korbicz, K. Patan, A. Obuchowicz, "Dynamic neural networks for process modeling in fault detection and isolation systems," *International Journal of Applied Mathematics and Computer Science*, Vol. 9, No. 3, pp. 519- 546, 1999.
- [14] I. Al-Zyoud and K. Khorasani, "Neural network-based Actuator Fault Diagnosis for Attitude Control Subsystem of an Unmanned Space Vehicle," *International Joint Conference on Neural Networks*, Vancouver, Canada. pp 3686-3693. July, 2006.
- [15] Z. Li, L. Ma and K. Khorasani, "Dynamic Neural Network-Based Fault diagnosis for attitude control subsystem of a satellite," *PRICAI, LNAI 4099*, pp 308-318, Springer-Verlag Berlin Heidelberg 2006.
- [16] Z. Li, L. Ma and K. Khorasani, "Fault Detection in Reaction Wheel of a satellite using Observer-Based Dynamic Neural Networks" *ISSN 2005, LNCS 3498*, pp. 584-590, Springer- Verlag Berling Heidelberg, 2005.
- [17] T. Marcu, L Mirea and P. Frank, "Neural observer schemes for robust detection and isolation of process faults," *UKACC International Conference on Control'98*, September 1998. Conference Publication No. 455. IEEE, 1998.
- [18] P. C. Hughes, "Spacecraft Attitude Dynamics." John Wiley & Sons (1986).
- [19] V. Chobotov, "Spacecraft Attitude Dynamics and Control." Krieger Publishing Company. Malabar, Florida. USA. 1991.