

Contributions to Design of Systems Actuated by Shape Memory Active Elements

Daniel Amariei, Calin O. Miclosina, Ion Vela, Marius Tufoi and Cornel Mituletu

Abstract—Even it has been recognized that Shape Memory Alloys (SMA) have a significant potential for deployment actuators, the number of applications of SMA-based actuators to the present day is still quite small, due to the need of deep understanding of the thermo-mechanical behavior of SMA, causing an important need for a mathematical model able to describe all thermo-mechanical properties of SMA by relatively simple final set of constitutive equations. SMAs offer attractive potentials such as: reversible strains of several percent, generation of high recovery stresses and high power / weight ratios. The paper tries to provide an overview of the shape memory functions and a presentation of the designed and developed temperature control system used for a gripper actuated by two pairs of differential SMA active springs. An experimental setup was established, using electrical energy for actuator's springs heating process. As for holding the temperature of the SMA springs at certain level for a long time was developed a control system in order to avoid the active elements overheating.

Keywords—active element, actuator, model, Nitinol, prehension

I. INTRODUCTION

BASICALLY, shape memory alloys are functional materials. They are much more important for what they can do (as an action) than for what they are (as a material). SMAs recover their original induced shape when they exceed a transition temperature (and we are speaking about a narrow temperature band, not a single point) between a low-temperature phase and a high-temperature phase [1], being able to convert its shape to a pre-programmed structure.

In general, the shape memory event is based on the ability of the material to change its crystal structure, in other words transforming from one crystal structure to another. In shape

This work was supported by CNCSIS –UEFISCSU by project number PNII – IDEI 2544/2008

Daniel Amariei is with Center of Advanced Research, Design and Technology from Eftimie Murgu University of Resita, Piata Traian Vuia 1-4, 320085, Resita, Romania, (phone: +40-745-862-830; fax: +40-255-207501; e-mail: d.amariei@uem.ro).

Calin Miclosina is with Faculty of Engineering from Eftimie Murgu University of Resita, Piata Traian Vuia 1-4, 320085, Resita, Romania, (e-mail: c.miclosina@uem.ro).

Ion Vela is with Faculty of Engineering from Eftimie Murgu University of Resita, Piata Traian Vuia 1-4, 320085, Resita, Romania, (e-mail: i.vela@uem.ro).

Marius Tufoi is with Center of Advanced Research, Design and Technology from from Eftimie Murgu University of Resita, Piata Traian Vuia 1-4, 320085, Resita, Romania, (e-mail: m.tufoi@uem.ro).

Cornel Mituletu is with Center of Advanced Research, Design and Technology from from Eftimie Murgu University of Resita, Piata Traian Vuia 1-4, 320085, Resita, Romania, (e-mail: c.mituletu@uem.ro).

memory alloys this transformation is usually referred to as a martensitic transformation.

The term martensite takes its name from Adolf Martens (1850-1914) a German metallurgist who first discovered this structure in steels. Later it was discovered that this transformation between austenite and martensite phases was not limited to steel [2].

Martensitic transformations in shape memory alloys are of displacive type and transformation takes place between Austenite also usually referred to as the parent phase and [3] categorizes the austenite to martensite transformation into two parts: Bain Strain and lattice-invariant shear. The Bain Strain takes its name from Bain who in 1924 proposed it and refers to the necessary deformation needed to obtain the new atomic structure. A three dimensional representation of the Bain Strain is shown in Figure 1.

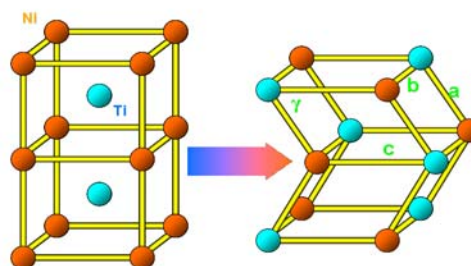

Fig. 1 Lattice deformation required for changing crystal structure

The second step of the martensitic transformation depicts the accommodation process required as a result of shape change. This process of accommodation called lattice invariant shear can be accomplished in two ways: slip and twinning (Figure 2).

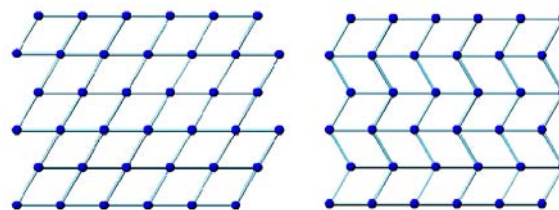

Fig. 2 Lattice invariant shear accommodation by slip (left) and twinning (right)

Slipping does not preserve all the bonds between the unit

atomic cells in the martensite making the transformation irreversible. On the other hand, twinning is a reversible process that allows the material to transform back to its parent phase. Since shape memory behaviour is a reversible process the accommodation mechanism that takes place in them is twinning. The mirroring plane on which twinning occurs is usually termed the twin boundary. Figure 3 depicts a twinned martensite state on which the order of the atoms is inherited from the austenite.

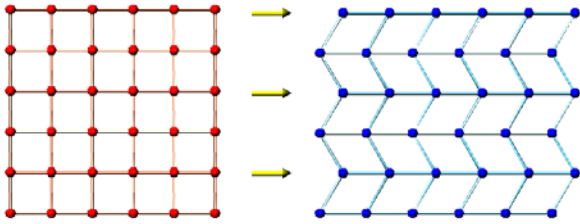

Fig. 3 Inherited order of atoms during martensite formation

Since twin boundaries can be readily moved, the inclusion of an external shear stress can alter the twinned martensitic state of the matrix to reflect only one variant of twinning as shown on Figure 4.

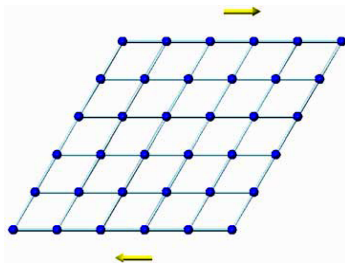

Fig. 4 De-twinned (deformed martensite) by the inclusion of shear stress

Although the previous review introduces the reader to the shape memory internals, it does not tell the entire picture. In practical terms the behaviour mentioned above is related to the temperature of the shape memory element, which determines its crystallographic state.

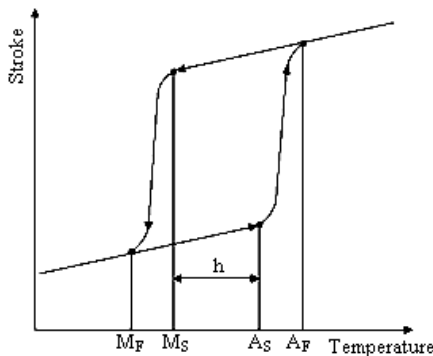

Fig. 5 Stroke -Temperature Relationship for Nitinol

A typical shape memory element has four relevant

temperatures that define the different stages of actuation, thus providing the designer a method for control. Simply put, the four temperatures (M_S , M_F , A_S , A_F) define the start and finish transformations for martensite and austenite (Figure 5).

Depending on the composition and processing of the alloy a special case of two way memory has been found and termed *All-around Memory Effect* [2].

In our researches we used this all-around memory effect [4], feature of this type of memory is that the low and high temperature shapes are complete opposites.

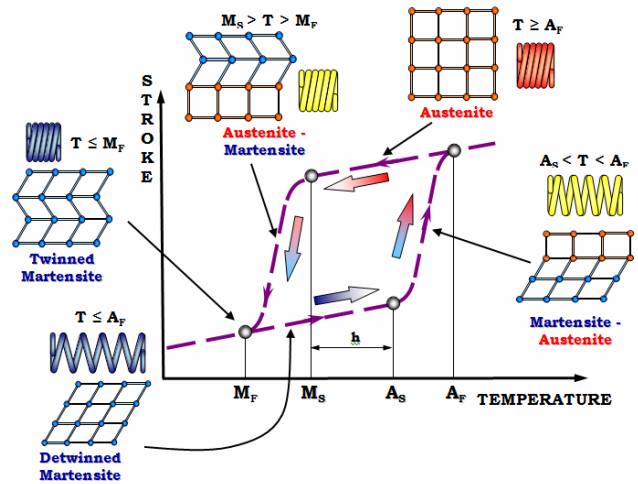

Fig. 6 All-around Memory Effect

The general technique for obtaining this type of memory effect for binary Ni-Ti is to deform the martensite beyond the limit, deform the parent phase more than is possible in a stress induced martensite transformation, deform the parent phase, cool the specimen to below the M_F temperature under restriction, and maintain this under stress for a long period of time, deform the martensite phase, heat the specimen under restriction, and induce the reverse transformation and finally deform the specimen after creating minute precipitates in the parent phase (Figure 6).

II. ACTUATOR DESIGN

A. The Active Nitinol Springs

Shape memory springs offer an increased amount of stroke at the expense of a reduced actuation force. The increased stresses that develop in the wire when setting this form can also potentially reduce its life considerable [5].

Even so, the chosen components of the developed actuator are two pair of Nitinol springs which action in an antagonistic way, heated by the electric current.

One pair of springs, namely the tension springs are made from wire of 750 μm diameter, the coil of the spring being 6 mm. The actuation current (2 A) activates them between 45^o-55^oC, each of the spring being able to lift 350 gr. The spring is deformed (Figure 7) at a temperature below M_F (A to B), followed by unloading (B to C) and again loading with a reaction R (C to D). Shape recovery occurs at an opposing

force R during heating to a temperature above A_F (D to E), so work is done [6].

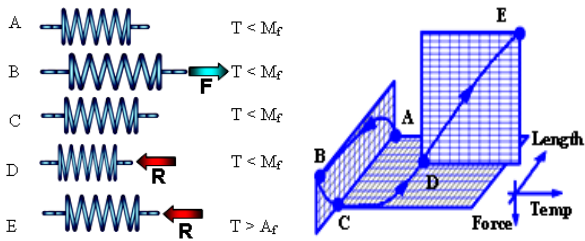

Fig. 7 Working principle of the Tension Springs

The other pair of springs, respectively the compression springs are made from wire of $950 \mu\text{m}$ diameter, forming a spring coil of 9 mm . They are activated at $55^\circ - 65^\circ\text{C}$ by a current of 3 A , developing a force exceeding 4 N . The sample is deformed (A to B) and unloaded (B to C) at a temperature below M_F . The residual deformation is restored during heating to a temperature above A_F (Figure 8).

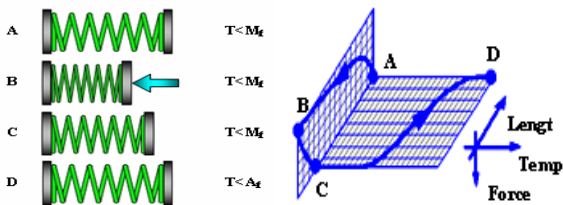

Fig. 8 Generation of shape recovery stresses in the compression springs

B. Model's behaviour

Results of displacement controlled simulations of the SMA model at various temperatures are presented in the diagrams below. The displacement is prescribed in the manner shown in Figure 9, except in the quasi-plastic case.



Fig. 9 Prescribed displacements vs. time for model behaviour description

Starting from an un-stretched condition, the simulated material is drawn out to some maximum extent and then permitted to return to a zero load condition [6]. To effectively remove the self-heating and self-cooling phenomena associated with the release and absorption of latent heats, the

simulation strain rate is very low, allowing ample time for temperature equilibration. This produces a nearly isothermal response. Further, the maximum displacement is chosen to guarantee a full phase transition to M^+ at full extension for the temperatures chosen.

At a low temperature, the quasi-plastic material behaviour is intrinsically captured by the model. Figure 10 (model stress-strain curve 20°C) shows the simulated load-deformation result in the tensile quadrant only. The initial phase composition is assumed to be equal proportions of the two martensite variants. Clearly, there is a remnant deformation as the material returns to a zero load condition, which dictates an early termination of the displacement curve of Figure 9.

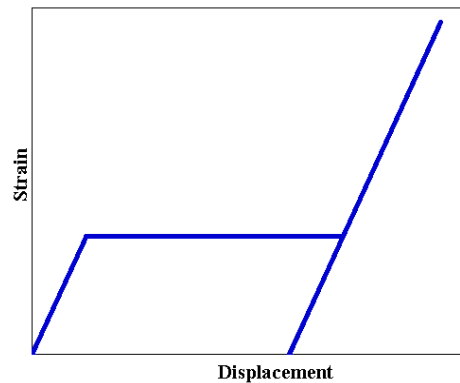

Fig. 10 Model stress-strain curve at 20°C

As shown in the figure, the initially linearly elastic material response is followed by a large displacement coinciding with a single load value, and then regains its elastic behaviour on further displacement. The zero slope region of the plot corresponds to the phase transition where M^- lattice layers flip to the M^+ orientation. Upon unloading, these newly formed M^+ layers do not retransform to their original orientation, but instead find equilibrium in this configuration, leading to the remnant deformation. That the slope of the curve starting from the origin is the same as the slope along which the material returns to a zero load condition indicates that the initial phase composition was purely martensitic.

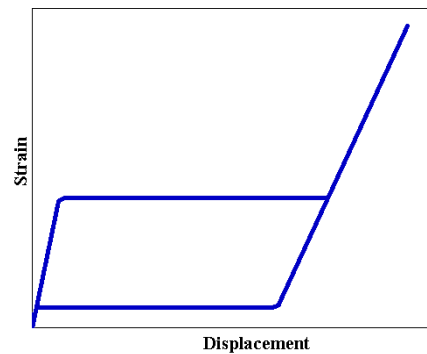

Fig. 11 Model stress-strain curve at 40°C

Figure 11 (model stress-strain curve 40°C) shows the load-

deformation curve at a higher temperature, where the material shows a pseudo-elastic response. Austenite is the stable phase under no load. Here again the initial response is linearly elastic, though the slope of the elastic region is much steeper than that observed at the lower temperature. This reproduces experimentally observed behaviour and indicates that a purely austenitic phase composition is significantly stiffer than a purely martensitic composition.

Note that the load at which the A→M transformation occurs is higher than that shown for the quasi-plastic case. This demonstrates the model's ability to capture the temperature dependence of the transition stress. Once the A→M phase transition is complete, further deformation traces the same linear path as the lower temperature. However, as the deformation returns to zero, the material spontaneously undergoes a retransformation to austenite at a low load level. At the end of the simulation, the material has returned to its original, un-stretched and unloaded condition, at the same time regaining a purely austenitic phase composition. The hysteresis loop circumscribed by the prescribed deformation is quite clear.

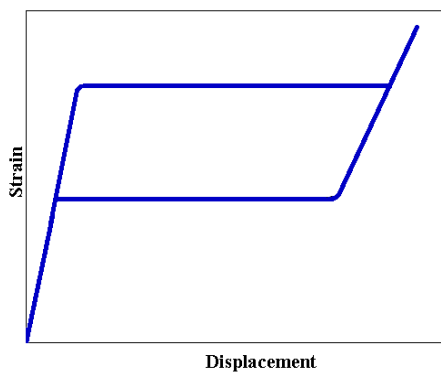

Fig. 12 Model stress-strain curve at 50°C

The next plot (model stress-strain curve 50⁰ C) shows the load-deformation curve of a simulation at yet a higher temperature. The salient differences in this case are the increases in the transition stresses. Both the A→M and the M→A phase transitions occur at substantially higher load levels than either of the two previous cases. However, the width of the hysteresis loop remains the same as the lower temperature, reproducing the experimentally observed behaviour.

These three simulations clearly demonstrate that the model is capable of reproducing the temperature-dependent nature of the material behaviour, as well as the hysteresis loops produced during cyclic loading where phase transformations occur. It is the model's intrinsic ability to capture the temperature dependence of the material response, as well as its ability to calculate that response from a prescription of deformation, that makes it particularly suitable for use in representing a SMA actuator in a deformation-based finite element environment.

C. Electric Command

The actuator control system based on SMA current should ensure optimal parameters necessary for prehension, but has not exceed the maximum power dissipated in the active element, which would lead to overheating and loss induced effect.

Respecting the imposed energy restriction, SMA's control systems can be achieved by implementing circuits in pulse width modulation (PWM). Such a circuit has been proposed in the literature [7].

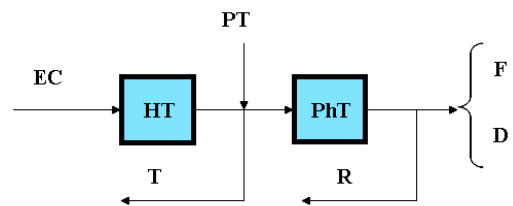

Fig. 13 Control circuit's functional blocks

Figure 13 shows the extensive control circuit's functional blocks, where EC - electric current, HT- heating temperature, PhT - phase transfer, F - force, D – displacement, R - SMA resistivity and T - SMA temperature.

SMA behaviour can be described by four variables: temperature, electrical resistance, generated force and displacement.

Figure 14 depicts a block diagram of a simple SMA's control system but able to meet the requirements of this stage of experimentation, leading to the establishment of a long time current variation and consequently the variation of resistance depending on time, where PC - computer, μP - microcontroller, PT - power transistor, SMA - shape memory alloy, TS - temperature sensor and LR - limitation resistivity.

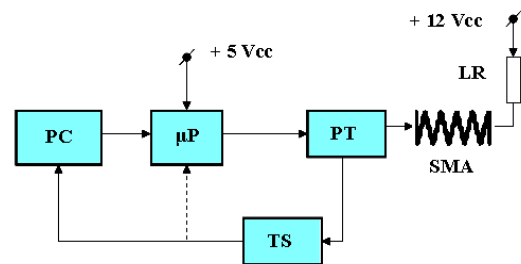

Fig. 14 Control System Scheme

Implementing a control system with the internal variable resistance has the following advantages: small hysteresis, the behaviour is approximately linear, easy to avoid the alloy overheating. In practice it is proposed a control method that combines internal resistance and the size of the displacement to implement a feedback control algorithm.

It also uses a control model to compensate shape memory alloys high hysteresis. This is done by using the feed-forward predictive power involving active element so as to achieve the desired movement.

The literature [8] treats several types of controllers for shape memory alloy actuators. The classic controller used is PI (proportional - integrative) but the controller's performance is determined by hand applied settings.

PI algorithm involves two distinct parameters, proportional and integral value, determining the proportionate amount response to current error and determining the response to the integrated value sum recent errors. Weighted sum of these two measures is used to adjust the process via a control element such as mains electricity to a heater.

By "setting" of the two constants in the PI algorithm's controller, it can carry out checks for specific requirements of process. Controller's response can be described according to a reactivity controller's error, the degree of overshoot of the reference point and the oscillation of the system. It must be emphasized that use PI as an element of control algorithm guarantees an optimal control on the system or system stability.

III. EXPERIMENTAL ANALYSIS

The main input and output parameters and which characterise the SMA actuator state are the material characteristics (chemical composition, mechanical and electrical characteristics, size of memory effect), their geometrical characteristics (form, length, section) and specific parameters of the heating and cooling process.

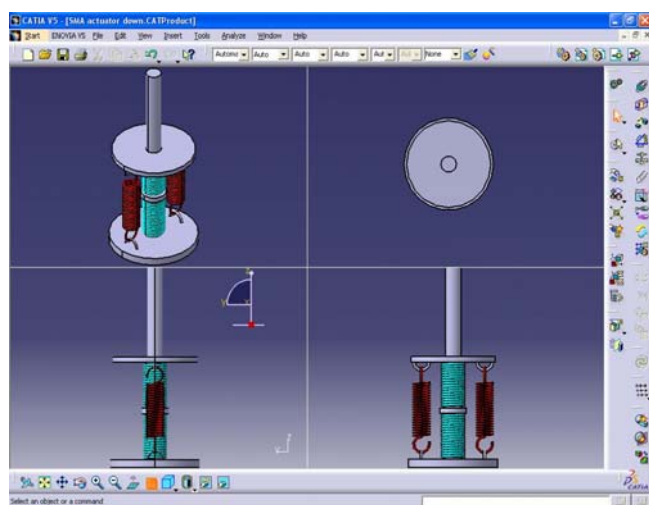

Fig. 15 Actuator in position with tension springs activated

Function of these input parameters, the active elements are in one of the already presented estates, characterised by certain values of the state parameters (strain-stress state, electrical resistivity, instantaneous temperature) [9].

The output parameters of the actuators are the displacement value, the developed force or torque and working cycle's frequency [10].

The actuator was able to perform a maximum stroke of 35 mm, lifting a weight of 400 grams. The relations between the characteristics of the gripper and the cooling methods, the heating current and the action frequency were studied

TABLE I
WORKING VALUES FOR THE TWO TYPES OF ACTIVE SPRINGS

	Tension	Compression
Lifted weight [gr]	350	400
Dynamic acting period [sec]	10	12
Voltage [V]	1.8	2.8
Current variation [A]	1.75 → 2	2.65 → 3
Resistance variation [Ω]	1.03 → 0.9	1.07 → 0.9
Strain [mm]	30	35
Variation type	hyperbolic	hyperbolic

experimentally. Furthermore, the position's control of the SMA actuator will be developed.

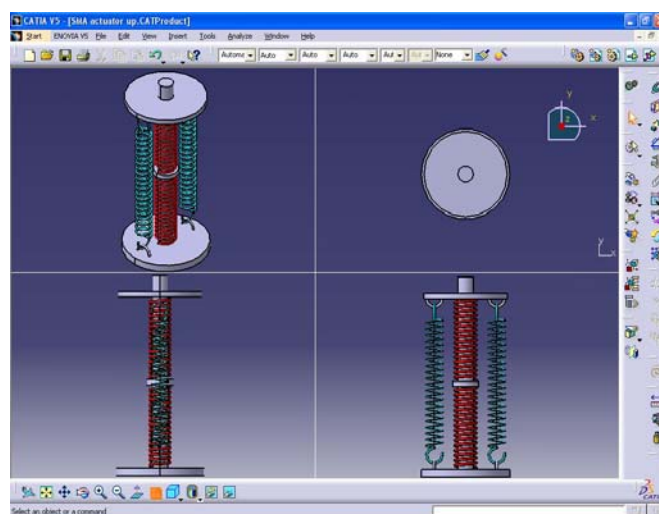

Fig. 16 Actuator in position with compression springs activated

A. Temperature Control

At this stage of experimentation, the microcontroller was used only for adjusting the active element SMA transmitted energy. The control system contains a ATmega8 AVR microcontroller, which allows the generation of PWM pulses on three separate channels. The operating principle stands as follows: - PWM pulses are applied to a IRFL640xxx MOS FET transistor in order to activate the SMA spring, the MOS FET transistor withstanding a maximum current of 17 A and a voltage of 200 V.

For proper functioning of the microcontroller it has been used the reset circuit and an oscillator circuit with a 4MHz quartz. Two voltage supplies of 12V and 5V were provided. The scheme also contains an XTEMP series electronic temperature measuring laser equipment which is able to transmit values via USB. The microcontroller could be programmed using the STK200 programmer, communication with the PC being via RS232 protocol.

As results of experiments was obtained that the tension springs have to be supplied for 10 sec at 2 A in order to reach the 52⁰ C, followed by a value of 0.9 A as long as necessary for prehension, while for compression springs, the values are 12 sec at 3 A in order to reach the 64⁰ C, followed by a value of 1.6 A.

IV. CONCLUSION

From the performed researches resulted that SMAs possess highly nonlinear and hysteretic constitutive behaviours showing a strong dependence on strain, temperature, and strain rate, making them viable as actuators in many applications, particularly those that are weight critical, that require a high force and high stroke under severe space restrictions.

The „shape memory” effect offers these materials an inherent actuation capability combining high strains with an exceptional specific work output, leading the list in maximum actuation stress and rival even hydraulics in specific work output. This is the highest specific work output amongst all known smart materials.

SMA thermal actuators are much simpler and much easier to be realized than other types of actuators, the control of temperature being possible to be realised in a simple manner, but present the disadvantage of a reduced operating speed. The specific actuator designing steps are: dimensioning active elements in function of the imposed source and force; dimensional and structural synthesis of the associated mechanical structure; designing the activation (heating and cooling) and the command and control system.

Important to notice is that the design of shape memory applications always require a specific approach, completely different from the design with structural materials. Progress over the past is promising which can be specifically related to understanding and analytically describing SMAs' constitutive behaviour.

The experimental device was realized to investigate the characteristics of the SMA springs and finally, the actuator for the robotic gripper, which can achieve the opening and closing motion of the two jaws easily.

Performances of the SMA gripper have been observed experimentally, whose dependence on the cooling methods, the heating current, and the action frequency has been investigated. The output displacement amplitude can increase by increasing the heating current and decreasing the action frequency during the SMA transformation process.

A PI controller is presented to control the output temperature of the springs, in which a control method was developed in order to reduce the overshooting of the system. Based on the acquired results, the temperature control can be realised very precise, in this way being possible to predict the actuator's developed displacement and prehension force. The following researches will take into consideration the displacement feedback, the proposed position controller to achieve a good control performance and high positioning accuracy, which are typical requirements for a gripper's actuators.

Furthermore, the positioning control of the SMA actuator is to be developed.

REFERENCES

- [1] Gilbertson, R.G., *Muscle Wires Project Book*, Mondo Tronics, CA, 2000.
- [2] H. Funakubo, ed. translated from Japanese by J.B. Kennedy, *Shape Memory Alloys*, Gordon and Breach Science Publishers, Amsterdam, Holland, 1987.
- [3] T.W. Duerig, C. M. Wayman, "An Introduction to Martensite and Shape Memory," *Engineering Aspects of Shape Memory Alloys*, Butterworth-Heinemann Publishers, London, pp. 3-20, 1990.
- [4] J. Perkins, and D. Hodgson, "The Two Way Shape Memory Effect," *Engineering Aspects of Shape Memory Alloys*, Butterworth-Heinemann Publishers, London, pp. 195-206, 1990.
- [5] D. Stöckel, Int. on New Actuators, Actuator, Bremen, 79-84, 1992.
- [6] Micloşină, C.; Vela, I.; Gillich, G.-R.; Amariei D. & Vela, D., "On the use of robotic grippers with shape memory alloy actuators in handling light-weight workpieces"- the 18th international DAAAM symposium, 24-27th October, pp. 451-452, 2007.
- [7] N. Ma, G. Song, Control of shape memory alloy actuator using pulse width modulation, *Smart Materials & Structures* 12 712, 2003.
- [8] D. Reynaerts, H. Van Brussel, Design aspects of shape memory actuators, *Mechatronics*, No. 8, pp. 635-656, 1998.
- [9] Wang, J.H.; Xu, F.; Yan, S.Z.; & Wen, S.Z., "Electrothermal Driving Mechanism for SMA Spring Actuators" *Materials Science Forum*, 423-424; 461-465, 2003.
- [10] D. Reynaerts, H. Van Brussel, Design aspects of shape memory actuators, *Mechatronics*, No. 8, pp. 635-656, 1998.