

# A Study on Early Prediction of Fault Proneness in Software Modules using Genetic Algorithm

Parvinder S. Sandhu, Sunil Khullar, Satpreet Singh, Simranjit K. Bains,  
Manpreet Kaur, Gurvinder Singh

**Abstract**—Fault-proneness of a software module is the probability that the module contains faults. To predict fault-proneness of modules different techniques have been proposed which includes statistical methods, machine learning techniques, neural network techniques and clustering techniques. The aim of proposed study is to explore whether metrics available in the early lifecycle (i.e. requirement metrics), metrics available in the late lifecycle (i.e. code metrics) and metrics available in the early lifecycle (i.e. requirement metrics) combined with metrics available in the late lifecycle (i.e. code metrics) can be used to identify fault prone modules using Genetic Algorithm technique. This approach has been tested with real time defect C Programming language datasets of NASA software projects. The results show that the fusion of requirement and code metric is the best prediction model for detecting the faults as compared with commonly used code based model.

**Keywords**—Genetic Algorithm, Fault Proneness, Software Fault and Software Quality.

## I. INTRODUCTION

HIGH assurance and complex mission-critical software systems are heavily dependent on reliability of their underlying software applications. A software fault prediction is a proven technique in achieving high software reliability. Prediction of fault-prone modules provides one way to support software quality engineering through improved scheduling and project control. Quality of software is increasingly important and testing related issues are becoming crucial for software. Although there is diversity in the definition of software quality, it is widely accepted that a project with many defects lacks quality. Methodologies and techniques for predicting the testing effort, monitoring process costs, and measuring results can help in increasing efficiency of software testing. Being able to measure the fault-proneness of software can be a key step towards steering the software testing and improving the effectiveness of the whole process.

A software fault is a defect that causes software failure in

an executable product. For each execution of the software program where the output is incorrect, we observe a failure. Software engineers distinguish software faults from software failures. Faults in software systems continue to be a major problem. Many systems are delivered to users with excessive faults. This is despite a huge amount of development effort going into fault reduction in terms of quality control and testing. It has long been recognized that seeking out fault-prone parts of the system and targeting those parts for increased quality control and testing is an effective approach to fault reduction. A limited amount of valuable work in this area has been carried out previously. Despite this it is difficult to identify a reliable approach to identifying fault-prone software components. Using software complexity measures, the techniques build models, which classify components as likely to contain faults or not. The modeling techniques applied cover the main classification paradigms, including principal component analysis, discriminate analysis, logistic regression, logical Quality will be improved as more faults will be detected. Predicting faults early in the software life cycle can be used to improve software process control and achieve high software reliability. Timely predictions of faults in software modules can be used to direct cost-effective quality enhancement efforts to modules that are likely to have a high number of faults. Prediction models based on software metrics, can estimate number of faults in software modules. Software metrics are attributes of the software system and may include process, product, and execution metrics. Various attributes, which determine the quality of the software, include maintainability, defect density, fault proneness, normalized rework, understandability, reusability etc.

With real-time systems becoming more complex and unpredictable, partly due to increasingly sophisticated requirements, traditional software development techniques might face difficulties in satisfying these requirements. Future real-time software systems may need to dynamically adapt themselves based on the run-time mission-specific requirements and operating conditions. This involves dynamic code synthesis that generates modules to provide the functionality required to perform the desired operations in real-time. However, this necessitates the need to develop a real-time assessment technique that classifies these dynamically generated systems as being faulty/fault-free. A variety of software fault predictions techniques have been

Dr. Parvinder S. Sandhu is working as Professor with the Rayat & Bahra Institute Of Engineering & Bio-Technology, Mohali-Sahauran14004. E-Mail: parvinder.sandhu@gmail.com.

Sunil Khullar is working with the Rayat Institute Of Engineering & Information Technology, Rail Majra, Ropar, Punjab, India.

Satpreet Singh & Gurvinder Singh are doing M.Tech CSE from RIEIT, Rail Majra, Punjab.

Simranjit Kaur Bains & Manpreet Kaur are associated with CEC Landran, Punjab, India.

proposed, but none has proven to be consistently accurate. These techniques include statistical method, machine learning methods, parametric models and mixed algorithms as discussed in [1]-[22].

Genetic algorithm is being successfully applied for solving both classification and regression problems. It is therefore important to investigate the capabilities of this algorithm in predicting software quality. In order to perform the analysis we validate the performance of the GA method for dataset derived from the NASA's MDP (Metric Data Program) data repository. Hence, The aim of proposed study is to explore whether metrics available in the early lifecycle (i.e. requirement metrics), metrics available in the late lifecycle (i.e. code metrics) and metrics available in the early lifecycle (i.e. requirement metrics) combined with metrics available in the late lifecycle (i.e. code metrics) can be used to identify fault prone modules using Genetic Algorithm technique.

## II. METHODOLOGY

The methodology consists of the following steps:

### A. Find the structural code and requirement attributes

The first step is to find the structural code and requirement attributes of software systems i.e. software metrics. The real-time defect data sets are taken from the NASA's MDP data repository, available online at <http://mdp.ivv.nasa.gov.in> named as PC1 dataset which is collected from a flight software from an earth orbiting satellite coded in C programming language, containing 1107 modules and only 109 have their requirements specified [23]. PC1 has 320 requirements available and all of them are associated with program modules. All these data sets varied in the percentage of defect modules, with the PC1 dataset containing the least number of defect modules.

### B. Select the suitable metric values as representation of statement

The suitable metrics like product requirement metrics and product module metrics out of these data sets are considered. The product requirement metrics are as follows:

- Module
- Action
- Conditional
- Continuance
- Imperative
- Option
- Risk\_Level
- Source
- Weak\_Phrase

The product module metrics are as follows:

- Module
- Loc\_Blank
- Branch\_Count
- Call\_Pairs
- LOC\_Code\_and\_Comment

- LOC\_Comments
- Condition\_Count
- Cyclomatic\_complexity
- Cyclomatic\_Density
- Decision\_Count
- Edge\_Count
- Essential\_Complexity
- Essential\_Density
- LOC\_Executable
- Parameter\_Count
- Global\_Data\_Complexity
- Global\_Data\_Density
- Halstead\_Content
- Halstead\_Difficulty
- Halstead\_Effort
- Halstead\_Error\_EST
- Halstead\_Length
- Halstead\_Prog\_Time
- Halstead\_Volume
- Normalized\_Cyclomatic\_Complexity
- Num\_Operands
- Num\_Operators
- Num\_Unique\_Operands
- Num\_Unique\_Operators
- Number\_Of\_Lines
- Pathological\_Complexity
- LOC\_Total

### C. Analyze, refine metrics and normalize the metric values

In the next step the metrics are analyzed, refined and normalized and then used for modeling of fault prediction in software systems. PC1 static code based dataset contains 43 static code metrics of which various metrics that do not impact binary classification are removed like module identifier, call pairs, condition count, cyclomatic density, Decision count, Decision density, Edge count, Essential density, etc and the remaining 22 have been used for training and testing data. In the requirement based dataset the number of Input Metrics are eight.

### D. Combine Requirement and code metrics

Combining requirements and code metrics have done using inner join database operation. An inner join creates a new result table by combining column values of two tables (A and B) based upon the join-predicate. The query compares each row of A with each row of B to find all pairs of rows which satisfy the join-predicate. When the join-predicate is satisfied, column values for each matched pair of rows of A and B are combined into a result row.

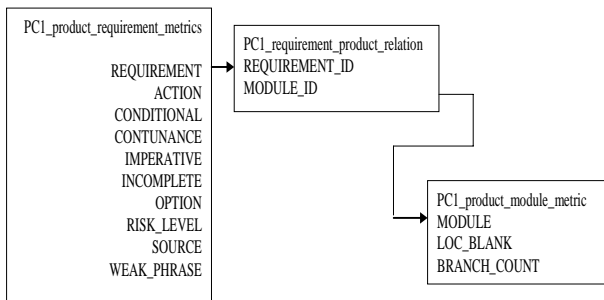

Fig. 1ER diagram relates project requirements to modules and modules to faults

In figure1 ER diagram relates the inner join between product\_requirement\_metric, product\_requirement\_relation and product\_module\_metric. The result of the join can be defined as the outcome of first taking the Cartesian product (or cross-join) of all records in the tables (combining every record in table A with every record in table B) - then return all records which satisfy the join predicate. Application of this operation to join requirement and code is possible using three metrics product\_module\_metrics, product\_requirement\_metrics and product\_requirement\_realtion. Join operation is performed onproduct\_module\_metrics and product requirement relation using common attribute Module ID and result is stored in temporary table. Then taking all records from temporary table and joining with product\_requirement\_metrics using Requirement ID. After joining of PC1 static code based dataset contains 43 static code metrics with 8 requirement based metrics and thereafter polishing in the joined dataset there are 31 total input metrics.

#### E. Identification of the Important Attributes

Correlation-based Feature Subset Selection is used for the evaluate the worth of a subset of attributes by considering the individual predictive ability of each feature along with the degree of redundancy between them. Hence, subsets of features that are highly correlated with the class while having low intercorrelation are preferred and are identified using BestFirst Algorithm [25].

BestFirst Searches the space of attribute subsets by greedy hillclimbing augmented with a backtracking facility. Setting the number of consecutive non-improving nodes allowed controls the level of backtracking done. Best first may start with the empty set of attributes and search forward, or start with the full set of attributes and search backward, or start at any point and search in both directions (by considering all possible single attribute additions and deletions at a given point) [25].

#### F. Genetic algorithm for classification of the software components into faulty/fault-free systems

Genetic algorithms are used in search and optimization,

such as finding the maximum of a function over some domain space.

- In contrast to deterministic methods like hill climbing or brute force complete enumeration, genetic algorithms use randomization.
- Points in the domain space of the search, usually real numbers over some range, are encoded as bit strings, called chromosomes.
- Each bit position in the string is called a gene.
- Chromosomes may also be composed over some other alphabet than {0, 1}, such as integers or real numbers, particularly if the search domain is multidimensional.
- GAs are called "blind" because they have no knowledge of the problem.

An initial population of random bit strings is generated.

- The members of this initial population are each evaluated for their fitness or goodness in solving the problem.
- If the problem is to maximize a function  $f(x)$  over some range  $[a, b]$  of real numbers and if  $f(x)$  is nonnegative over the range, then  $f(x)$  can be used as the fitness of the bit string encoding the value  $x$ .

From the initial population of chromosomes, a new population is generated using three genetic operators: reproduction, crossover, and mutation.

- These are modeled on their biological counterparts.
- With probabilities proportional to their fitness, members of the population are selected for the new population.
- Pairs of chromosomes in the new population are chosen at random to exchange genetic material, their bits, in a mating operation called crossover. This produces two new chromosomes that replace the parents.
- Randomly chosen bits in the offspring are flipped, called mutation.

The new population generated with these operators replaces the old population.

- The algorithm has performed one generation and then repeats for some specified number of additional generations.
- The population evolves, containing more and more highly fit chromosomes.
- When the convergence criterion is reached, such as no significant further increase in the average fitness of the population, the best chromosome produced is decoded into the search space point it represents.

Genetic algorithms work in many situations because of some hand waving called The Schema Theorem.

- Short, low-order, above-average fitness schemata receive exponentially increasing trials in subsequent generations."

In short genetic algorithm (GA) is a search technique used in computing to find exact or approximate solutions to

optimization and search problems. Genetic algorithms are categorized as global search heuristics. Genetic algorithms are a particular class of evolutionary algorithms (EA) that use techniques inspired by evolutionary biology such as inheritance, mutation, selection, and crossover. This Technique used the feature of random search. Random search feature selection searches the best possible solution over a range of data. Random features and input given produce good result. In the beginning start with a large “population” of randomly generated “attempted solutions” to a problem then repeatedly do the following:

- Evaluate each of the attempted solutions
- Keep a subset of these solutions (the “best” ones)
- Use these solutions to generate a new population
- Quit when you have a satisfactory solution (or you run out of time).

The flowchart of the Genetic algorithm used is shown below:

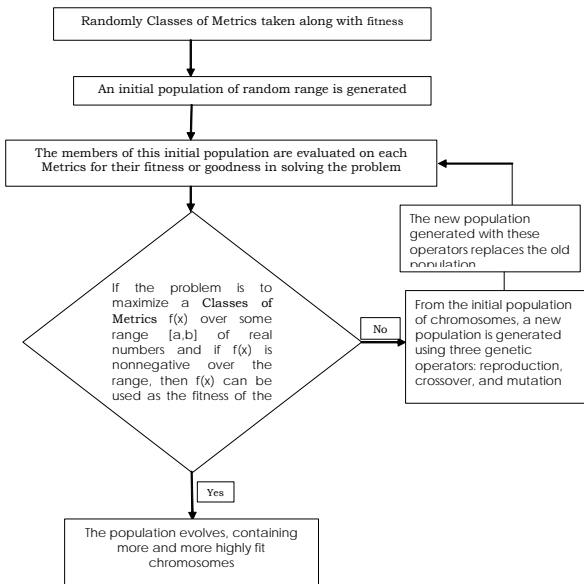

Fig. 2 Flowchart of Genetic Algorithm Used

G. Implementing the model and finding the result

The proposed approach is implemented in Visual Basic environment and MATLAB is used to calculate the performance of the algorithm.

H. Performance Criteria

The comparisons are made on the basis of the least value of Accuracy, MAE and RMSE values. The mean absolute error is chosen as the standard error. The technique having lower value of mean absolute error is chosen as the best fault prediction technique.

• *Mean absolute error:* Mean absolute error, MAE is the average of the difference between predicted and actual value in all test cases; it is the average prediction error [26]. The formula for calculating MAE is given in equation shown below:

$$\frac{|a_1 - c_1| + |a_2 - c_2| + \dots + |a_n - c_n|}{n} \tag{1}$$

Assuming that the actual output is a, expected output is c.

• *Root mean-squared error:* RMSE is frequently used measure of differences between values predicted by a model or estimator and the values actually observed from the thing being modeled or estimated [26]. It is just the square root of the mean square error as shown in equation given below:

$$\sqrt{\frac{(a_1 - c_1)^2 + (a_2 - c_2)^2 + \dots + (a_n - c_n)^2}{n}} \tag{2}$$

The mean-squared error is one of the most commonly used measures of success for numeric prediction. This value is computed by taking the average of the squared differences between each computed value and its corresponding correct value. The root mean-squared error is simply the square root of the mean-squared-error. The root mean-squared error gives the error value the same dimensionality as the actual and predicted values.

The mean absolute error and root mean squared error is calculated for each machine learning algorithm.

III. RESULTS AND DISCUSSIONS

The NASA MDP datasets are used in this approach to estimate the quality of a software product. The dataset used is PC1. We used requirement metrics, code metrics and join the requirement and code metrics as specified in [24] for modeling. First, the CFS algorithm is applied to the evaluate the worth of a subset of attributes by considering the individual predictive ability of each feature along with the degree of redundancy between them. The direction of the BestFirst search is set to the Forward direction and the maximum size of the lookup cache of evaluated subsets is set to 1. This is expressed as a multiplier of the number of attributes in the data set. The snapshot of results of CFS algorithm applied on Combined dataset and code based dataset is shown in figure 3 and figure 4.

```

Attribute Selection on all input data ===
Search Method:
Best first.
Start set: no attributes
Search direction: forward
Stale search after 5 node expansions
Total number of subsets evaluated: 287
Merit of best subset found: 0.362

Attribute Subset Evaluator (supervised, Class (numeric): 32 Faulty/Non-Faulty):
CFS Subset Evaluator
Including locally predictive attributes

Selected attributes: 4,12,23,25,30,31 : 6
Metric4
Metric12
Metric22
Metric24
Metric29
Metric30
    
```

Fig. 3 Snapshot of Result of CFS Algorithm applied on Combined Dataset.

== Attribute Selection on all input data ==

Search Method:

- Best first.
- Start set: no attributes
- Search direction: forward
- Stale search after 5 node expansions
- Total number of subsets evaluated: 153
- Merit of best subset found: 0.318

Attribute Subset Evaluator (supervised, Class (numeric): 22 Faulty/Non-Faulty):

- CFS Subset Evaluator
- Including locally predictive attributes

Selected attributes: 14,15,16,18 : 4

- Metric14
- Metric15
- Metric16
- Metric18

Fig. 4 Snapshot of Result of CFS Algorithm applied on Code Based Dataset.

The CFS algorithm has proposed 6 significant attributes and 4 significant attributed in the combined dataset and code based dataset respectively for the predication of fault prone modules.

Thereafter, the significant attributes are taken further analysis. In case of the combined dataset the statistics of the attributes selected is shown below:

Field Name	Min Range	Min Range	Length
Metric4	0	48	6
Metric12	0.01	8.65	4
Metric22	0	7	3
Metric24	0	1	1
Metric29	1	3	2
Metric30	1	23	5

Fig. 5 Statistics of the selected attributes for the Combined Dataset

In case of the code based dataset the statistics of the attributes selected is shown in figure 6.

Field Name	Min Range	Min Range	Length
Metric14	0	159	8
Metric15	0	48	6
Metric16	0	225	8
Metric18	0	538	10

Fig. 6 Statistics of the selected attributes for the Code Based Dataset.

The Genetic algorithm based fault proneness prediction system is developed in Visual Basic 6.0 and the Graphical User Interface developed and loaded with the selected combined dataset and code based dataset is shown in figure 7 and 8 respectively.

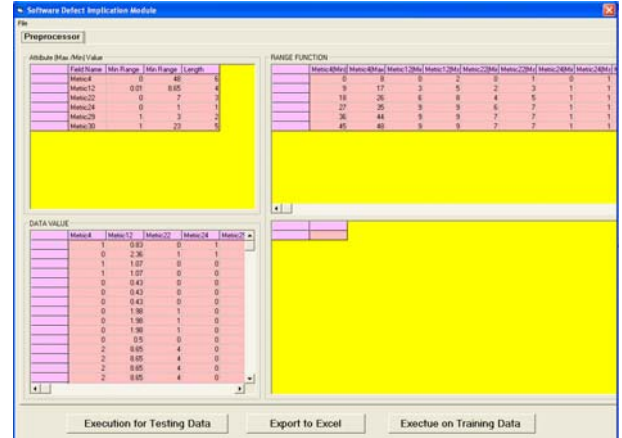

Fig. 7 Developed GUI loaded with the selected Combined Dataset

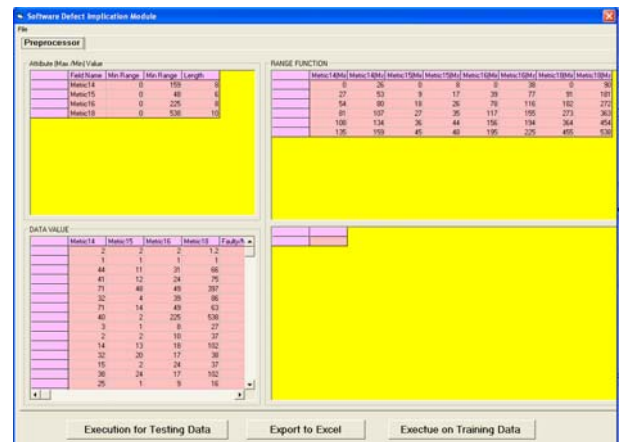

Fig. 8 Developed GUI loaded with the selected Code based Dataset

The interface is further used to predict the fault proneness of the examples after the training. Thereafter, the MATLAB based routine is used to calculate the performance criteria Accuracy %, MAE and RMSE values. The results recorded are shown in Table I.

TABLE I  
PERFORMANCE OF PREDICTION OF FAULT PRONENESS

Performance Criteria	PCI Dataset	
	Code Based Dataset	Combined Code and Requirement Dataset
Accuracy	92.8765	97.0650
MAE	0.0712	0.0294
RMSE	0.2669	0.1713

#### IV. CONCLUSION

In this study we predict that knowing the fault prone data at early stages of lifecycle combined with data available during code can help the project managers to build the projects with more accuracy and it will reduce the testing efforts as faulty areas are already predicted, so these modules can be handled properly.

The results of the fusion or combined model are better with 97.0650, 0.0294 and 0.1713 as Accuracy, MAE and RMSE values respectively as compared to 92.8765, 0.0712 and 0.02669 values in case of code based model.

Hence, Data available in the early stages can help the analyst to plan the required resources as and when required for development, testing. However, further investigation can be done and the impact of attributes on the fault prediction can be found. Also, more algorithms can be evaluated and then we can find the best algorithm.

## REFERENCES

- [1] Saida Benlarbi, Khaled El Emam, Nishith Geol (1999), "Issues in Validating Object-Oriented Metrics for Early Risk Prediction", by Cistel Technology 210 Colonnade Road Suite 204 Nepean, Ontario Canada K2E 7L5.
- [2] Fenton, N. E. and Neil, M. (1999), "A Critique of Software Defect Prediction Models", Bellini, I. Bruno, P. Nesi, D. Rogai, University of Florence, IEEE Trans. Softw. Engineering, vol. 25, Issue no. 5, pp. 675-689.
- [3] Bellini, P. (2005), "Comparing Fault-Proneness Estimation Models", 10th IEEE International Conference on Engineering of Complex Computer Systems (ICECCS'05), vol. 0, 2005, pp. 205-214.
- [4] Giovanni Denaro (2000), "Estimating Software Fault-Proneness for Tuning Testing Activities" Proceedings of the 22nd International Conference on Software Engineering (ICSE2000), Limerick, Ireland, June 2000.
- [5] Mahaweerawat, A. (2004), "Fault-Prediction in object oriented software's using neural network techniques", Advanced Virtual and Intelligent Computing Center (AVIC), Department of Mathematics, Faculty of Science, Chulalongkorn University, Bangkok, Thailand, pp. 1-8.
- [6] Ma, Y., Guo, L. (2006), "A Statistical Framework for the Prediction of Fault-Proneness", West Virginia University, Morgantown.
- [7] Thomas Zimmermann, Nachiappan Nagappan (2008), "Predicting Defects Using Social Network Analysis on Dependency Graphs", International Conference on Software Engineering (ICSE 2008), Leipzig, Germany.
- [8] Audris Mockus, Nachiappan Nagappan and Trung T. Dinh-Trong, (2009) "Test Coverage and Post-Verification Defects: A Multiple Case Study," ACM-IEEE Empirical Software Engineering and Measurement Conference (ESEM), Orlando, FL, 2009.
- [9] Cagatay Catal & Banu Diri (2009), "A Systematic Review of Software Fault Prediction Studies" Journal of Expert Systems with Applications, Volume 36, Issue 4, May 2009.
- [10] Jonas Boberg (2008), "Early Fault Detection with the Model-based Testing", 7th ACM SIGNPLAN workshop on ERLANG, 2008.
- [11] Bindu Goel & Yogesh Singh (2008), "Empirical Investigation of Metrics for Fault Prediction on Object Oriented Software" the Book series in Computational Intelligence, 2008.
- [12] Khoshgoftaar, T. M., Allen, E. B., Ross, F. D., Munikoti, R., Goel, N. & Nandi, A. (1997), "Predicting fault-prone modules with case-based reasoning". ISSRE 1997, the Eighth International Symposium on Software Engineering (pp. 27-35), IEEE Computer Society (1997).
- [13] Min-Gu Lee and Theresa L. Jefferson (2005), "An Empirical Study of Software Maintenance of a Web-based Java Application", Proceedings of the 21st IEEE International Conference on Software Maintenance (ICSM'05), IEEE (2005).
- [14] Marco D' Ambros and Michle Lanza (2006), "Software Bugs and Evolution: A Visual Approach to uncover their relationship", Proceedings of IEEE Conference on Software Maintenance and Reengineering (CSMR' 06), IEEE (2006).
- [15] George E. Stark (1996), "Measurements for Managing Software Maintenance", IEEE computer Society, 1996.
- [16] Khoshgoftaar, T.M. and Munson, J.C. (1990), "Predicting Software Development Errors using Complexity Metrics", Selected Areas in Communications, IEEE Journal on, Volume: 8 Issue: 2, Feb. 1990, Page(s): 253 -261.
- [17] Menzies, T., Ammar, K., Nikora, A., and Stefano, S. (2003), "How Simple is Software Defect Prediction?" Submitted to Journal of Empirical Software Engineering, October (2003).
- [18] Eman, K., Benlarbi, S., Goel, N., and Rai, S. (2001), "Comparing case-based reasoning classifiers for predicting high risk software components", Systems Software, Journal of, Volume: 55 Issue: 3, Nov. (2001), Page(s): 301 – 310.
- [19] Fenton, N.E. and Neil, M. (1999), "A critique of software defect prediction models", Software Engineering, IEEE Transactions on, Volume: 25 Issue: 5, Sept.- Oct. 1999, Page(s): 675 -689.
- [20] Khoshgoftaar, T. M. and Seliya, N. (2002), "Tree-based software quality estimation models for fault prediction", METRICS 2002, the Eighth IEEE Symposium on Software Metrics (pp. 203-214). IEEE Computer Society 2002.
- [21] Seliya N., Khoshgoftaar, T.M., Zhong S. (2005), "Analyzing software quality with limited fault-proneness defect data", Ninth IEEE international Symposium on 12-14 Oct, 2005.
- [22] Lan Guo, Bojan Cukic, Harshinder Singh (2003), "Predicting Fault Prone Modules by the Dempster-Shafer Belief Networks," ase, pp.249, 18th IEEE International Conference on Automated Software Engineering (ASE'03), 2003.
- [23] NASA IV &V Facility. Metric Data Program. Available from <http://MDP.ivv.nasa.gov/>.
- [24] Jiang Y., Cukic B. and Menzies T. (2007), "Fault Prediction Using Early Lifecycle Data". ISSRE 2007, the 18th IEEE Symposium on Software Reliability Engineering, IEEE Computer Society, Sweden, pp. 237-246.
- [25] Hall M. A. (1998), Correlation-based Feature Subset Selection for Machine Learning. Hamilton, New Zealand, 1998.
- [26] Challagulla V.U.B., Bastani F.B., Yen I. L. and Paul (2005) "Empirical assessment of machine learning based software defect prediction techniques", 10th IEEE International Workshop on Object-Oriented Real-Time Dependable Systems, USA, pp. 263-270