

Modeling and Parametric Study for CO₂/CH₄ Separation using Membrane Processes

Faizan Ahmad, Lau Kok Keong, Azmi Mohd. Shariff

Abstract—The upgrading of low quality crude natural gas (NG) is attracting interest due to high demand of pipeline-grade gas in recent years. Membrane processes are commercially proven technology for the removal of impurities like carbon dioxide from NG. In this work, cross flow mathematical model has been suggested to be incorporated with ASPEN HYSYS as a user defined unit operation in order to design the membrane system for CO₂/CH₄ separation. The effect of operating conditions (such as feed composition and pressure) and membrane selectivity on the design parameters (methane recovery and total membrane area required for the separation) has been studied for different design configurations. These configurations include single stage (with and without recycle) and double stage membrane systems (with and without permeate or retentate recycle). It is shown that methane recovery can be improved by recycling permeate or retentate stream as well as by using double stage membrane systems. The ASPEN HYSYS user defined unit operation proposed in the study has potential to be applied for complex membrane system design and optimization.

Keywords—CO₂/CH₄ Separation, Membrane Process, Membrane modeling, Natural Gas Processing

I. INTRODUCTION

METHANE is the major component (75%-90%) of natural gas but it may also contain significant amounts of ethane, propane, butane and traces of higher hydrocarbons depending upon the source [1]. In some deposits, it may have contaminants such as CO₂, H₂S, CO which constitutes environmental hazards and also causes hindrance in natural gas processing. The upgrading of low quality crude natural gas is attracting interest due to the high demand for pipeline-grade gas in recent years. CO₂ must be removed in order to serve the following purposes; increase the heating value of the gas, prevent corrosion of pipeline and process equipments and crystallization during liquefaction process [2, 3].

CO₂ contents can vary from 4% to 50% in NG depending upon the gas source. It needs to be pre-processed before the transportation to meet the typical pipeline specification of 2%-5% CO₂ [4]. Most of the NG, produced in the lower 48 states of USA, contains more than 5% CO₂. As a result, many natural gas wells are unexploited due to their low production rate and low quality (i.e., high CO₂ and/or H₂S content) [5].

Faizan Ahmad is with the Chemical Engineering Department, Universiti Teknologi PETRONAS, Bandar Sri Iskandar, 31750 Tronoh, Perak Malaysia. (Ph. No: 0060-13-4056022; e-mail: faizan615@gmail.com).

Lau Kok Keong is with the Chemical Engineering Department, Universiti Teknologi PETRONAS, Bandar Sri Iskandar, 31750 Tronoh, Perak Malaysia. (e-mail: laukokkeong@petronas.com.my).

Azmi Mohd. Shariff is with the Chemical Engineering Department, Universiti Teknologi PETRONAS, Bandar Sri Iskandar, 31750 Tronoh, Perak Malaysia. (e-mail: azmish@petronas.com.my).

In Malaysia, NG from Tangga Barat Cluster fields of PETRONAS contains relatively high amount of CO₂ [6]. Therefore, it is necessary to develop efficient processes for the removal of CO₂ from NG [5, 6].

There are different processes for the removal of CO₂ considering the factors of; capital and operating costs, gas specifications and environmental concerns. The major processes can be grouped as absorption Processes (chemical and physical absorption), adsorption processes (solid surface), hybrid solution (mixed physical and chemical solvent) and Physical Separations (membrane and cryogenic Separation) [7, 8, 9].

For natural gas processing applications, membranes processes are commercially proven technology. For a gas to permeate through a membrane surface, the gas must first dissolve in the high-pressure side of the membrane, diffuse across the membrane wall, and evaporate from the low-pressure side. The working principle of gas separation is therefore that some gases are more soluble in, and pass more easily through polymeric membrane than other gases [7, 10, 11].

In membrane process, feed gas is pretreated before entering the membrane system in order to ensure efficient operation. It mainly controls the fouling, plasticization and condensation of hydrocarbons in the membranes [1, 11]. Moreover, the temperature control system is provided to maintain the gas at the desired operating temperature of the membrane fibers. Finally, the heated gas is entered into the membrane gas separators where it gets separated into two streams; the permeate, a low pressure CO₂ stream and the non-permeate or residue, a high pressure hydrocarbon rich stream [7].

Gas separation by membrane technology has become a major industrial application only during the last few decades but the study of gas separation has a long history [10]. Graham measured the permeation rates of all the known gases of that time using different diaphragms [10, 12]. Barer, Amerongen and Stern played an important role in the development of solution diffusion model for the explanation of gas permeation [13, 14, 15]. The success of Monsanto, the first membrane company, encouraged other companies like Cvnai, Separex and Grace Membrane Systems to produce membrane plants for removal of CO₂ from natural gas [10, 16].

Datta and Sen worked on the optimization of the gas processing cost for a membrane unit. It is shown that the optimum configuration might be unique within certain ranges of CO₂ concentration and the minimum gas processing cost could only be achieved by adjusting the number of modules in each stage and the compressor power [4].

Lee et al. investigated the effects of the operating variables of pressure, feed flow rate, and the carbon dioxide concentration in the feed. Additionally, computer models were applied for the separation of gases under perfect mixing and cross flow conditions to the analysis of the field data [5]. Wang enhanced operational flexibility and adaptability of membrane process using an optimal method in which auto-controlling of the permeate gas flux was applied for the first time [17].

Qi and Hensen presented the optimal design strategy for spiral membrane networks for gas separations [18] whereas Lababidi developed the mathematical model to optimize three configurations including single stage, two stages, and the continuous membrane column (CMC) [19].

The permeability and selectivity variations of the CO₂/CH₄ system have been studied by Safari, Ghanizadeh and Rehmat that included both temperature and pressure effects simultaneously [20]. Hau et al. studied process design, economics, and sensitivity of membrane stage with recycle streams [21].

There are limited studies on the design of membrane system using commercial process simulator. The advantages of using commercial simulator involve the accurate modeling of thermodynamics properties and auxiliary equipment in the membrane system. In this paper, different design parameters are analyzed for membrane gas separation under different configurations using ASPEN HYSYS. As membrane unit is not a pre-defined unit operation in ASPEN HYSYS, a cross flow model is proposed to predict the membrane performance in the removal of CO₂ from natural gas. Finally, the proposed model is included in the process simulation as user defined unit operation along with other available unit operations to design the membrane system.

II. METHODOLOGY

A. Governing equations

The study is based on the cross flow model derived by Weller and Steiner [22] as shown in the detailed flow diagram (Fig. 1). The nomenclature of the flow sheet is as follows:

- $dV = dL$ = Total flow rate permeating through the area
- x_f = Feed mole fraction
- x_0 = Retentate mole fraction
- y_n = Permeate mole fraction
- L_f = Feed flow rate
- L_r = Retentate flow rate
- V_n = Permeate flow rate
- p_h = Pressure on the high pressure side
- p_l = Pressure on the low pressure side

The model assumes no mixing in the permeate side as well as on the high pressure side. Thus the composition of permeate can be determined at any point along the membrane by the relative permeation rates of feed component at that point [23].

The assumptions that follow the suggested model are:

1. It holds for the binary gas mixture
2. Permeability is independent of pressure and temperature of the gas stream.

3. It represents the whole membrane module and will not involve the details inside the module.
4. Pressure drop on both sides of the membrane is negligible.
5. The concentration polarization is assumed to be negligible.

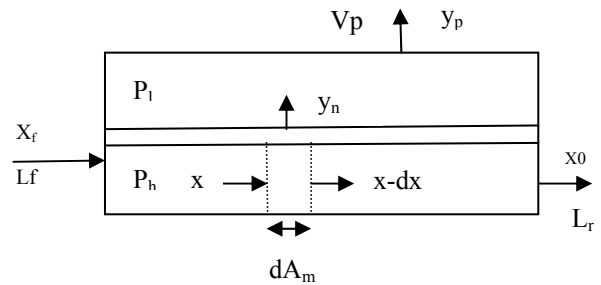

Fig. 1 Schematic diagram of cross flow membrane separation

The local permeation rate at any point in the stage over a differential membrane area dA_m is

$$y dV = \frac{P_A}{t} [p_h x - p_l y] \tag{1}$$

$$y dV = \frac{P_B}{t} [p_h (1 - x) - p_l (1 - y)] \tag{2}$$

Dividing eq (i) by eq (ii), we get

$$\frac{y}{1-y} = \frac{\alpha [x - (p_l - p_h) y]}{(1-x) - \left(\frac{p_l}{p_h}\right) (1-y)} \tag{3}$$

Using ingenious transformations, an analytical solution to the three equations (eq. (i) - eq. (iii)) have been obtained [10].

$$\frac{(1-\theta^*)(1-x)}{(1-x_f)} = \left[\frac{U_f - \frac{E}{D}}{U - \frac{E}{D}} \right] R \left[\frac{U_f - \alpha + F}{U - \alpha + F} \right] S \left[\frac{U_f - F}{U - F} \right] T \tag{4}$$

Where

$$\theta^* = 1 - L/L_f \text{ (L as flow rate permeated in the differential element)}$$

$$i = \frac{x}{(1-x)}$$

$$u = -Di + (D^2 i^2 + 2Ei + F^2)^{0.5}$$

$$D = 0.5 \frac{(1-\alpha)p_l}{p_h} + \alpha$$

$$E = (\alpha/2) - DF$$

$$F = -0.5 \frac{(1-\alpha)}{p_h} p_l - 1$$

$$R = 1 / (2D - 1)$$

$$S = \frac{\alpha(D-1) + F}{(2D-1) - \left(\frac{\alpha}{2} - F\right)}$$

$$T = \frac{1}{1 - D - \left(\frac{E}{F}\right)}$$

The term u_f is the value of u at $i = i_f = x_f / (1 - x_f)$. The value of θ^* is the fraction permeated up to the value of x . At the outlet where $x = x_0$, the value of θ^* becomes equal to θ i.e., the total fraction permeated. The composition of the permeate stream is y_p and thus can be calculated from the overall material balance.

$$y_p = \frac{x_f - x_0(i - \theta)}{\theta} \tag{5}$$

The total membrane area is then calculated using additional transformations of eqs. (i)-(v) in order to obtain

$$A_m = \frac{tL_f}{p_h P_B} \int_{i_0}^{i_f} \frac{(1 - \theta^*)(1 - x) di}{(f_i - i) \left[\frac{1}{1+i} - \frac{P_l}{P_h} \left(\frac{1}{1+f_i} \right) \right]}$$

Where

$$f_i = (Di - F) + (D^2i^2 + 2Ei + F^2)^{0.5}$$

The term i_f is the value of i at the feed and i_0 is the value of i at the outlet. The integral is solved numerically to calculate the value of total membrane area required for the separation.

B. Design Configurations

The design of a membrane separation process involves (i) the configuration of permeators (ii) the operating parameters of the individual permeators [18]. Different configurations have been proposed for the membrane separation as shown in Fig. 2. For moderate purity and recovery requirement, single stage system (with and without recycle) is appropriate [24]. For more demanding separations, multiple stage system is required [25, 26]. It is a conventional approach to select different configurations and then optimize the operating permeation [19].

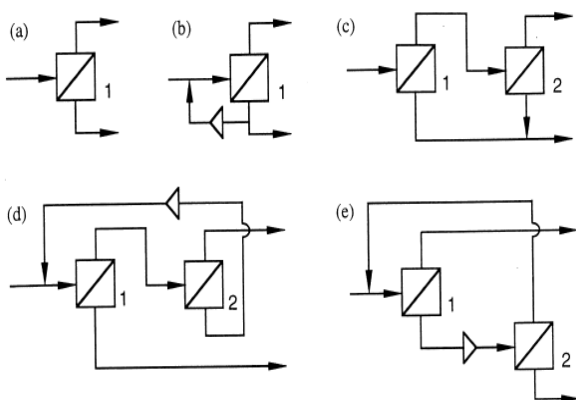

Fig. 2 Design configurations for CH₄/CO₂ separations: (a) single stage (b) Single stage with recycle (c) two stage (d) Two stage with permeate recycle (e) Two stage with retentate recycle.

III. RESULTS AND DISCUSSIONS

A. Model Validation

A mathematical model is validated with the published experimental data for membrane separation process. The data by Pan et al. [27] is based on the experiments done on sour natural gas. The feed gas contains 48.5 % CO₂ that is removed in the permeate stream, with the purpose to increase the recovery of methane in the retentate stream. The temperature and pressure of the gas are 10oC and 35.28 bar respectively whereas, on the other hand, the permeate pressure is 9.28 bar. The selectivity is assumed to be 25. Table 1 shows that the suggested model gives good approximation to the experimental data with maximum percentage error < 17.8%.

The proposed model is further validated with the data from Liu et al [28] based on the study conducted on propylene enrichment using cross flow membrane. Table 2 show that the simulated data are in close agreement with the experimental data with maximum percentage error < 5 % . It can also be observed that the simulated model gives better approximation with experimental data from Liu et al. as compared to experimental data from Pan et al. [28]. The small error in the comparison can be attributed to the sensitivity of membrane permeability towards high pressure, which is assumed negligible in the suggested mathematical model.

TABLE I
VALIDATION OF MATHEMATICAL MODEL WITH EXPERIMENTAL DATA BY PAN et al

Stage Cut (□)	Permeate mole fraction, CO ₂		
	Simulated	Experimental	% Error
0.40	0.91	0.96	5.49
0.42	0.88	0.95	7.95
0.45	0.83	0.94	13.25
0.47	0.81	0.93	14.8
0.50	0.78	0.91	16.6
0.52	0.75	0.89	18.6
0.55	0.73	0.86	17.8

TABLE II
VALIDATION OF MATHEMATICAL MODEL WITH EXPERIMENTAL DATA BY LIU et al.

Stage Cut (□)	Mole fraction of Species in permeate		
	Simulated	Experimental	% Error
0.01	0.80	0.76	5.00
0.02	0.78	0.76	2.56
0.03	0.77	0.76	1.29
0.04	0.78	0.75	3.8

B. Parametric analysis:

The methane recovery and total membrane area are considered as the main parameters for membrane system design. The effects of feed composition, feed pressure and

the selectivity of the membrane were studied on the methane recovery for different configurations using the suggested cross-flow model.

Effect of feed composition:

Methane recovery decreases with the increase in CO₂ contents of the feed [18]. At the same time, methane recovery can be improved by recycling the permeate or recycle stream as well as using double stage configurations [24, 29, 30].

The effect of feed composition on methane recovery for all proposed configurations, for the stage cut of 0.5 and selectivity of 25, is shown in Fig. 3 (a). The feed pressure and permeate pressure are maintained at 100 and 4 bar respectively. The permeability of CH₄ is considered as 1.4×10^{-3} mol/MPa-m²-s.

It can be observed that the methane recovery is reducing with the increase of CO₂ in the feed gas. The systems without recycle, as expected, provide the lowest CH₄ recovery. It is obvious as the portion of first stage permeate that is lost is taken from the first membrane module, where feed CO₂, hence permeate CO₂ is highest and hydrocarbons are lowest. Besides, the simulated results also show that the usage of two stage system could minimize the reduction of CH₄ recovery under high CO₂ feed composition.

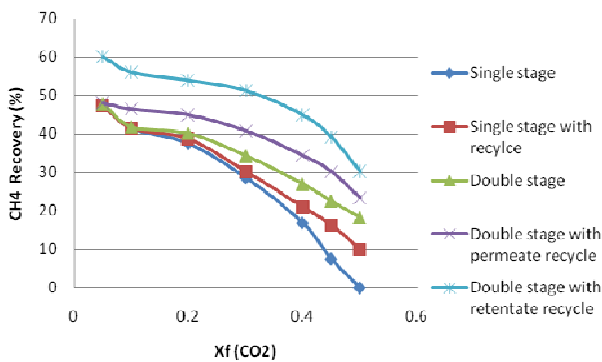

Fig. 3 (a) Effect of feed composition on methane recovery

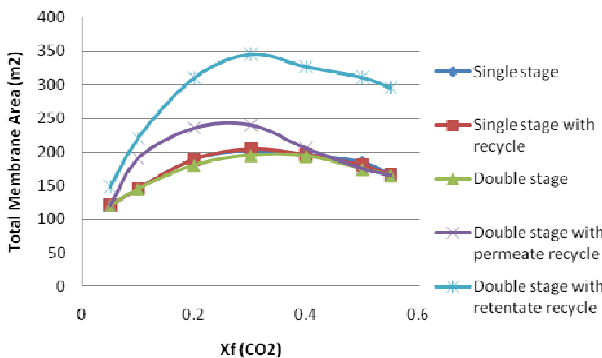

Fig. 3 (b) Effect of feed composition on total membrane area

The total membrane area required for the effective separation increases with the increase in CO₂ composition of the feed until its maximum point reaches. After that, further increase can lead to decrease in the membrane area requirement as shown in fig. 3(b). It can also be observed that recycling the

retentate stream in double stage configuration can lead to large requirements of area, while in single stage, recycling has not much effect. These results are consistent with those obtained by Qi et al [18].

Effect of feed pressure:

The increase in feed pressure improves methane recovery [11, 18]. It is due to the fact that the increment of pressure creates a greater driving force across the membrane. As a result, a net increase in permeation through the membrane increases methane recovery under present selectivity.

Fig. 4(a) shows the effect of feed pressure on methane recovery for different configurations. The stage cut and selectivity is same as in previous case, whereas the feed gas contains 20% CO₂ and 80% CH₄. The increase in feed pressure increases the methane recovery, especially when the pressure is less than 70 bar. Based on the figure, the double stage configurations with recycles stream give the high recovery followed by double stage without recycle. Similarly single stage with recycle stream is observed with high methane recovery, though less than the double stage configurations, in comparison to single stage without recycle stream.

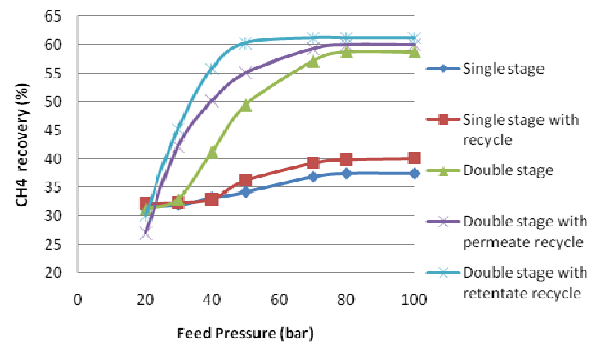

Fig. 4(a) Effect of feed pressure on methane recovery

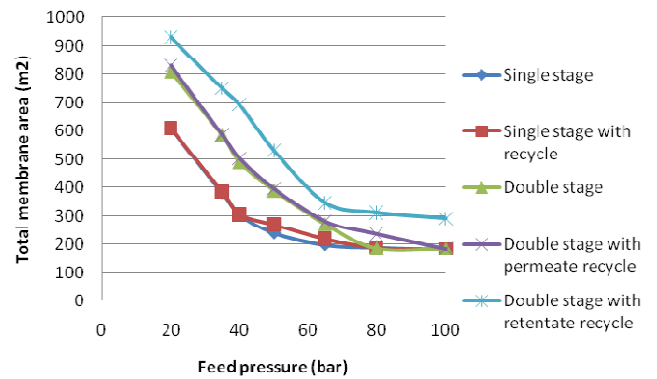

Fig. 4 (b) Effect of feed pressure on total membrane area

On the other hand, an increase in feed pressure would decrease the total membrane area required for the effective separation as shown in the fig. 4(b). It is obvious as high pressure leads to high rate of permeation which directly reduce the membrane area required for the separation.

Effect of membrane selectivity:

Membrane properties have high influence on methane recovery. Methane recovery increases with the increase in selectivity of the membrane [18]. It is due to the reason that increased selectivity leads to higher permeation and thus improved methane recovery.

Fig. 5(a) shows the effect of membrane selectivity on the methane recovery for five proposed configurations. As expected, the increase in selectivity increases CH₄ recovery, especially for the double stage configurations and single stage with recycle stream. It can also be noted that the increment in selectivity for the single stage configuration is less significant on the methane recovery.

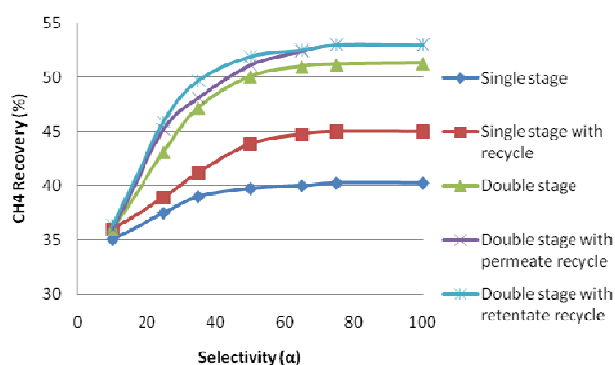

Fig. 5(a) Effect of membrane selectivity on methane recovery

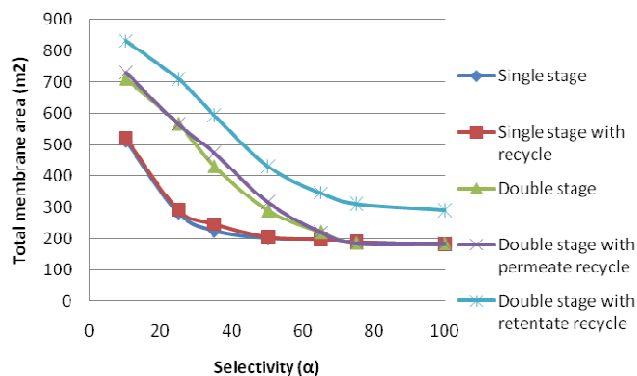

Fig. 5(b). Effect of selectivity on total membrane area

Moreover, Fig 5(b) shows the effect of membrane selectivity on the total membrane area for different configurations. Based on the figure, the increasing of selectivity decreases the membrane area requirements. The effect is more significant in double stage configuration with retentate recycle, followed by other double stage and single stage configurations.

IV. CONCLUSIONS

The design sensitivity of membrane separation system for CO₂/CH₄ separation has been investigated for different configurations including single stage (with and without recycle) and double stage membrane systems (with and without of permeate or retentate recycle). It is shown that methane recovery can be improved, on the expense of large membrane area, by recycling the permeate stream as well as using double stage configurations. Furthermore, CO₂

contents in the feed has high influence on the methane recovery as well as membrane area. The increased feed pressure and use of highly selective membranes can also lead to the improved methane recovery. Moreover, the membrane area required for the effective separation can be decreased by increasing the feed pressure or selectivity of the membrane, especially for low composition of CO₂ in natural gas. The ASPEN HYSYS user defined membrane unit operation proposed under present study potentially to be applied for complex membrane system design and optimization.

ACKNOWLEDGMENT

This work was done with the financial support from Universiti Teknologi PETRONAS.

REFERENCES

- [1] R. W. Baker and K. Lokhandwala, "Natural gas processing with membranes: an overview," *Industrial Engineering Chemistry Research*, Vol. 4, pp. 2109-202, Nov 2008.
- [2] J. Hao, P.A. Rice and S.A. Stern, "Membrane processes for the removal of acid gases from natural gas. II. Effects of operating conditions, economic parameters, and membrane properties", *Journal of Membrane Science*, Volume 81, Issue 3, pp. 239-252, June 1993.
- [3] M. H. Safari, A. Ghanizadeh, and M.M. Montazer-Rahmati, "Optimization of membrane-based CO₂-removal from natural gas using simple models considering both pressure and temperature effects" *International Journal of Greenhouse Gas Control*, Vol. 3, pp. 3-10, 2008.
- [4] A.K. Datta and P.K. Sen, "Optimization of membrane unit for removing carbon dioxide from natural gas," *J. Membr. Sci.* Vol. 283, pp. 291-298, 28 June 2006.
- [5] A.L. Lee, H.L. Feldkirchner, S. A. Stern, A.Y. Houde, J.P. Gomez, and H.S. Meyer, "Field tests of membrane modules for the separation of carbon dioxide from low quality natural gas", *Gas sep. Purif.*, pp 35-43. Vol. 9, 10 May 1994.
- [6] PETRONAS media releases & news 2008. Available: <http://www.petronas.com.my/internet/corp/news.nsf/2b372b45ff1ab3a48256b42002b19a7/d9473b4fd966e901482574eb002b3fce?OpenDocument> (Accessed on 10th Jan. 2010)
- [7] S.A. Ebenezer, "Removal of Carbon dioxide from natural gas for LPG production", *Semester project work*. Institute of Petroleum Technology, Norwegian University of Science & Technology, Trondheim, Norway. 2005.
- [8] R.N. Maddox, *Gas and Liquid Sweetening*, 2nd ed., Campbell Petroleum series (1974).
- [9] W.J. Koros and R.T. Chern, "Separation of gaseous mixtures using polymer membranes, in: R.W. Rousseau (Ed.)," *Handbook of Separation Process Technology*, Wiley, New York, 1987, pp. 863-953
- [10] R.W. Baker, *Membrane Technology and Application*, 2nd ed., John Wiley & Sons, Chichester, UK, pp. 287-295, 2004.
- [11] A.F. Ismail, "Specialized workshop on membrane gas separation technology", Advanced Membrane Technology Research Centre, Universiti Teknologi Malaysia, 2009.
- [12] T. Graham, "On the absorption and dialytic separation of gases by colloid septa", *Philos. Mag.*, Vol. 32, 1866, pp. 401
- [13] R.M. Barrer, *Diffusion in and through solids*. Cambridge University Press, London, 1951.
- [14] G.J. van Amerongen, "Influence of structure of Elastomers on their permeability to gases," *J. Appl. Poly. Sci.*, Vol. 5, p 307, 1950.
- [15] S.A. Stern, "Industrial applications of membrane processes: The separation of gas mixtures," *Proceedings of the symposium southern Research Institute*, Brimingham, May 1966.
- [16] J. M. S. Hennis and M.K. Tripodi, "A novel approach to gas separations using composite hollow fibre membranes," *Sep. Sci. and Tech.* Vol. 15, p 1059, 1980.
- [17] L. Wang, C. Shao and H. Wang, "Operation optimization of a membrane separation process through auto-controlling the permeate gas flux." *Sep. Purif. Technol.* Vol. 55, p 30, 15 May 2007.

- [18] R. Qi and M.A. Hensen, "Optimal design of spiral wound membrane networks for gas separations", *Journal of membrane science*, Vol. 148, pp. 71-89, 22 May 1998.
- [19] H. Lababidi, A. Ghazi, Al-Enezi and Hisham M. Ettoney, "Optimization of module configuration in membrane gas separation," *Journal of membrane Science*, Vol 112, pp 185-197, 1996.
- [20] M.H. Safari, A. Ghanizadeh and M.M. Montazer-Rahamti, "Optimization of membrane based CO₂- removal from natural gas using simple models considering both pressure and temperature effects," *International Journal of Green House Control*, Vol. 105, May 2008.
- [21] J. Hao, P.A. Rice and S.A. Stern, "Upgrading low quality natural gas with H₂S and CO₂ selective polymer membranes Part II. Process design, economics, and sensitive study of membrane stages with recycle streams", *Journal of Membrane Science*, Vol. 320, pp. 108-122, 23 march 2008.
- [22] S. Weller and W.A. Steiner, "Separation of gases by fractional permeation through membranes", *Journal of Applied Physics*, Vol. 21, pp. 180-184, 1950.
- [23] C. J. Geankoplis, "Transport processes and separation process principles" fourth edition, Prentice Hall, New Jersey, 2003.
- [24] W.J. Schell and C.D. Houston, "Spiral-wound permeators for purification and recovery", *Chem. Eng. Prog.*, Vol. 13, pp. 33-37, October 1982.
- [25] R.W. Spillman, "Economics of gas separation membranes", *Chem. Eng. Prog.* Vol 85, pp. 41-62, Jan 1989.
- [26] A.B. Coady and J.A. Davis, "CO₂ recovery by gas permeation", *Chem. Eng. Prog.*, pp. 44-49, Oct. 1982.
- [27] C.Y. Pan, "Gas Separation by high flux, asymmetric hollow fiber membrane", *AIChE Journal*. Vol. 32, pp. 2020-2027, 1986.
- [28] L. Liu, A. Chakma and X. Feng, "propylene separation from nitrogen by poly (ether block amide) composite membranes", *Journal of membrane science*. Vol. 279, pp. 645-654, 2006.
- [29] R.W. Spillman, M.G. Barrett and T.E. Cooley, Gas membrane process optimization. In: AIChE National Meeting, New Orleans, LA, 1988
- [30] R.E. Babcock and R.W. Spillman, C.S. Goddin and T.E. Cooley, Natural gas cleanup: a comparison of membrane and amine treatment processes. *Energy Prog.* Vol. 8, pp. 135-142, 1988.