

Investigating the Transformer Operating Conditions for Evaluating the Dielectric Response

Jalal M. Abdallah

Abstract—This paper presents an experimental investigation of transformer dielectric response and solid insulation water content. The dielectric response was carried out on the base of Hybrid Frequency Dielectric Spectroscopy and Polarization Current measurements method (FDS & PC). The calculation of the water content in paper is based on the water content in oil and the obtained equilibrium curves. A reference measurements were performed at equilibrium conditions for water content in oil and paper of transformer at different stable temperatures (25, 50, 60 and 70°C) to prepare references to evaluate the insulation behavior at the not equilibrium conditions. Some measurements performed at the different simulated normal working modes of transformer operation at the same temperature where the equilibrium conditions. The obtained results show that when transformer temperature is much more than the its ambient temperature, the transformer temperature decreases immediately after disconnecting the transformer from the network and this temperature reduction influences the transformer insulation condition in the measuring process. In addition to the oil temperature at the near places to the sensors, the temperature uniformity in transformer which can be changed by a big change in the load of transformer before the measuring time will influence the result. The investigations have shown that the extremely influence of the time between disconnecting the transformer and beginning the measurements on the results. And the online monitoring for water content in paper measurements, on the basis of the oil water content on line monitoring and the obtained equilibrium curves. The measurements were performed continuously and for about 50 days without any disconnection in the prepared the adiabatic room.

Keywords—Conductivity, Moisture, Temperature, Oil-paper insulation, Online monitoring, Water content in oil.

I. INTRODUCTION

TRANSFORMER utilities try to keep the water at a low level inside their transformers. Water content is an important parameter for the safe operation, service life and reliability of a transformer. A code of practice is set and used by utilities for the maintenance of transformers. In accordance with these maintenance guides an accurate measurement of the moisture level in a transformer becomes an important factor in transformer maintenance.

Transformer oil is usually a highly-refined mineral oil that is stable at high temperatures and has excellent electrical insulating properties. The main uses are to insulate, suppress

corona and arcing, and to serve as a coolant. Nowadays it is important to use oil which does not cause ecological sequences.

Transformer mineral oils are refined from predominantly naphthenic crude oils. The refining processes could include acid treatment, solvent extraction, dewaxing, hydrogen treatment, or combinations of these methods to yield mineral insulating oil meeting the specification. It is mainly a mixture of hydrocarbon compounds of three classes: alkanes, naphthenes, and aromatic hydrocarbons.

These molecules have little or no polarity. Polar and ionic species are a minor part of the constituents, which may greatly influence the chemical and electrical properties of the oil. Polar compounds found in transformer oil usually contain oxygen, nitrogen, or sulfur. Ionic compounds would typically be organic salts which can be found only in trace quantities [1]. For a more complete review on transformer oil, refer to [2, 3, 4].

The most important factors are moisture and heat that deteriorate the insulation system of oil immersed power transformers and cause the reliability of these devices to be limited. During the lifetime of power transformer moisture content of oil, paper, and pressboard is increased as a result of transformer breathing in different load conditions as well as in consequence of decomposing the cellulosic materials under thermal stresses or because of aging phenomena.

The disturbance of moisture equilibrium results in a significant reduction of the electrical strength of the oil, especially if the transformer board has water content more than 2.5%. This value is normally in an ageing transformer. As with increasing water content within the oil, the breakdown voltage decreases.

Water has a strong influence on electric strength. In a wide range of relative humidity, the electric strength of clean insulating mineral oil, for temperatures higher than 0°C, falls practically exponentially as relative humidity [3, 5].

Transformer solid insulation can be divided into thin insulation and thick insulation. Thin insulation comprises turn insulation on the coil conductors made of paper (about 5% of the solid insulation) and barriers made of pressboard (about 20–30% of the solid insulation). Thick structure comprises basically supporting components and is generally between one third and one half of the solid insulation mass.

There is always a certain amount of water that can be not extracted during the transformer drying in factory. In addition,

Jalal Abdallah is with Tafila Technical University, Jordan. He is now Associate Prof. at the Department of Electrical Engineering, P.O. Box: 851229 code 11185, Amman, Jordan (e-mail: jalal_abdallah@hotmail.com).

the engrossed water from the atmosphere and aging water generated in the decomposition reactions of cellulose and oil can increase the transformer water. Due to the great difference in water affinity of oil and paper, the most of the water remains in solid insulation. Water distribution between paper and oil is not constant and depends on transformer condition and temperature. Moisture transfer can be activated by moisture concentration, temperature and pressure gradient.

When moisture in oil exceeds from the saturation value, free water appears. Oil saturation can take place when the temperature of the transformer decreases abruptly after a period of operation at high temperature in which an important amount of water has migrated from paper to oil (for example, when a highly loaded transformer is tripped off on a cold day). In these circumstances, oil solubility reduces quickly and water returns to paper. Nevertheless, the return is slower than the decrease of solubility, so the saturation value can be exceeded.

Water in paper may be found in four states: It may be adsorbed to surfaces, as vapor, as free water in capillaries, and as imbibed free water. The paper can contain much more moisture than oil. For example, a 150 MVA, 400 kV transformers with about seven tons of paper can contain as much as 223 kg of water about 3.2% [4, 6]. The oil volume in a typical power transformer is about 80,000 liters. Assuming a 20 PPM moisture concentration in oil, the total mass of moisture is about 2 kg, much less than in the paper.

For normal transformers water content measurement in oil can be achieved with different direct methods, but water content in paper can be only by indirect methods (non-destructively). Some of these indirect measurement methods for water content in paper are the Recovery Voltage Measurement (RVM), Frequency Domain Spectroscopy (FDS), Polarization, and Depolarization Current Measurements (PDC) [6]. These two later became only recently available as user-friendly methods, and can be used to monitor, diagnose and control of new insulating materials, qualification of insulating systems during/after production of power equipments non-destructively [6, 7].

Usually when a transformer is to be measured with the dielectric response method earlier mentioned, it is should be switched off the service and after a period of time the measurement begins. This time depend on the qualification of the human personal how is in charged to apply the process. That means the transformer inside parameters for this time changed specially the temperature and consequently the water content in oil and paper according to the further information. The following experiment was to emphasize that the time between the moment of stop and beginning the measurement is very important. Naturally the temperature of the transformer is higher than the surrounding temperature as it is on the load and after switching off service it is will slowing down. This decreasing in temperature caused changes in water content solubility for the insulation oil and paper. Therefore, there is a great need to create and develop the online mentoring and measuring methods of water content in paper.

A commercially moisture sensors are available and they can be used as on-line monitoring systems to measure inaccurately the oil temperature and the oil relative saturation. In the other hand, there are some equilibrium curves that can be used to calculate the water content in paper from the water content in oil at the equilibrium conditions and these calculated values of water content in paper can be used as the boundary values which can help to evaluate the condition of water content in insulation solid of transformer.

II. WATER CONTENT IN OIL AND PAPER

When a transformer works at a constant relatively elevated temperature for a long period, the thermodynamic equilibrium condition between cellulose water absorbed and oil water dissolved closely approached. This equilibrium is temperature dependent such that at elevated temperature more water dissolved by oil. The bulk of water is in the paper and any small change in transformer temperature significantly modify the dissolved water content of the oil but only slightly modify the water content of the paper. This causes an increase in the oil conductivity and a reduction in solid insulation performance and leads to a higher $\tan \delta$, which confirmed by the measurements.

This paper will report on an investigation into two methods devised for the calculation of moisture content of the paper. This will be achieved by using analytical results for moisture content of the oil at different temperatures and make a comparison of them with hybrid FDS&PC method.

The Relative humidity for oil is the dissolved water content of the oil relative to the maximum capacity of moisture that the oil can hold. The saturation ratio is a function of pressure, and especially of temperature in transformer [8, 9]. The relative humidity can be converted in to water concentration in ppm through expression (1).

$$W_{CO} = W_S .R.H(\%) \quad (1)$$

Where WCO is water concentration in ppm and WS is water solubility in ppm at temperature T.

A. Water Solubility

Solubility is defined as the total amount of water than can be dissolved in the oil at a specific temperature. Water in oil is usually in dissolution. It can also appear strongly bound to the oil molecules (especially in aged oil) [5]. Oil is highly hydrophobic, but the solubility of water in oil increases sharply with temperature. In Fig. 1, water solubility in oil is shown as a function of the temperature according to data given by Griffin [9]. As can be seen, oil is able to absorb a larger amount of water coming from the paper when the transformer becomes hotter [10,11].

The increase is not linear but exponential in function. For example, at 10°C only 36 ppm of water can be dissolved in the oil, whereas when the temperature increases to 90°C, the amount of water that can be dissolved in the oil increases tremendously to almost 600 ppm.

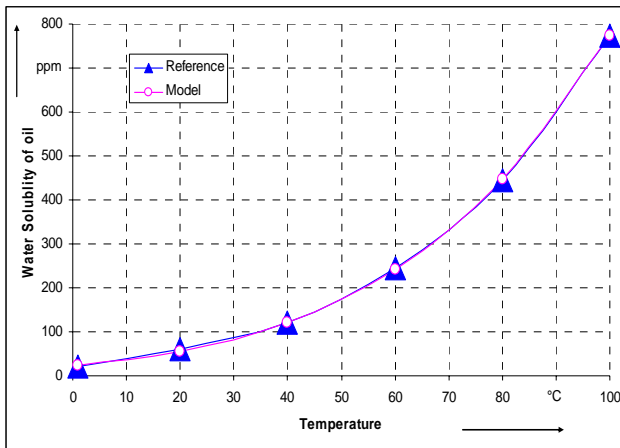

Fig. 1 Water solubility in oil versus temperature

Oil water content is directly proportional to the relative water concentration (relative saturation) up to the saturation level. The temperature dependence of the water solubility in oil (W_s) is expressed by:

$$W_s = A.e^{(-B/T)} \tag{2}$$

Where T is the temperature in Kelvin and A & B are constants that are similar for many transformer oils but may be different for some products, mainly due to differences in aromatic contents. As oil become much oxidized with increasing amounts of polar aging by-products, their water solubility characteristics also increases. The solubility in very aged oils is typically twice as much as the measured water in unused oils [12, 13].

The typical oil of the transformer under study is Shell DialaD. According to the measurements, the parameter can be calculated as $A=12283989$ and $B= 3609$. Result of this modelling is in the good agreement with the reference [green].

The water concentration from water activity (a_w) or Relative Humidity (RH%) using the user manual of the MM70 sensor calculated with equation (3).

$$W_{CO} = a_w \cdot 10^{(C+D/T)} \tag{3}$$

Where C and D are constant and they are -1663 and 7.369 respectively.

If the relative humidity of the oil is measured by commercially available sensors can be directly used to estimate the moisture concentration in the pressboard but this method is not very reliable in the low moisture range due to the impractical conditioning of paper below 10% relative humidity. Hence, Oommen used the data of the vapour pressure of water in the gas space in a sealed system reported by Beer et al. in 1966 and converted to relative humidity by the relationship by equation (4), [7].

$$R.H \% = \left(\frac{p}{p_0} \right) \cdot 100 \tag{4}$$

where p_0 is the saturated water vapour pressure and p is the water vapour pressure. Using the relation (1) and (4), the water content in oil can be expressed as equation (5):

$$\frac{W_{CO}}{W_s} = \left(\frac{p}{p_0} \right) \tag{5}$$

B. Water Concentration in internal Insulations

The equilibrium between water content of internal Insulations (paper) and oil has been widely studied by several authors [4, 12], who obtained equilibrium curves showing water content in paper versus water content in oil for different temperatures, so it is possible to determine the value of one of these variables once knowing the other two.

This equilibrium requires a long time to be attained. This time varies from hours to several days depending on temperature. Moreover, the time to equilibrium also depends on the direction of water flow (i.e., the process of water desorption from paper to oil is faster than the re-absorption of water by the paper).

The require time to reach an oil-paper insulation to equilibrium condition can be approximately estimated by the equation (6).

$$\tau = \frac{4d^2}{\pi^2 D} \tag{6}$$

where d represents the thickness of pressboard and D is the moisture diffusion coefficient and τ is the diffusion time constant for moisture diffusing from one side of solid insulation. The moisture diffusion coefficient can be calculated from the equation (7).

$$D = D_0 \cdot \exp [0.5 W_{CP} + E_a \cdot (1/T_0 - 1/T)] \tag{7}$$

where WCP presents the moisture content in paper and T is the oil temperature expressed in °K. The constants in equation (7) are $D_0 = 1.34E-13$ m²/s, $E_a = 8074$ °K and $T_0 = 298$.

A comparison of diffusion coefficients D and the diffusion time τ for an insulation thickness 2 mm for different water content in paper (from 1.0% to 5.0%) and temperature (from 0°C to 100°C) are given in Fig. 2 using Foss's formula.

Fessler et al. combined the data from Houtz, Ewart, Oommen and their own experiments and determined the water-paper equilibrium formula as following equation, [4]:

$$W_{CP} = 2.173 \cdot p^{-7} \cdot e^{0.6685} \cdot e^{(4725.61/T)} \tag{8}$$

where P, is the vapour pressure of water in atmosphere, WCP is the concentration of water in paper (g H₂O/g Paper), and T is the absolute temperature in degrees Kelvin.

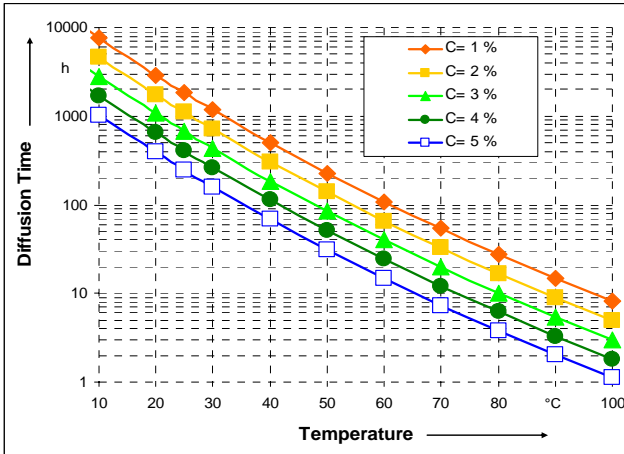

Fig. 2 The relation between the temperature and diffusion time for different levels of water contents using Foss's formula

By substituting equations (5) into (8), the water concentration in paper defined by the following equation:

$$W_{CP} = k_1 \cdot W_{CO}^{0.6685} \cdot e^{k_2/T} \tag{9}$$

where the k1 and k2 are constant and related to the water vapour saturation pressure.

C. Mathematical Model

To calculate the water content in paper, one of the best methods can be the use of the equilibrium curves and calculating the water content in paper on the base of the water content in oil. When a transformer working at normal load curve periodically, then the transformer can be considered at the equilibrium condition or near to it.

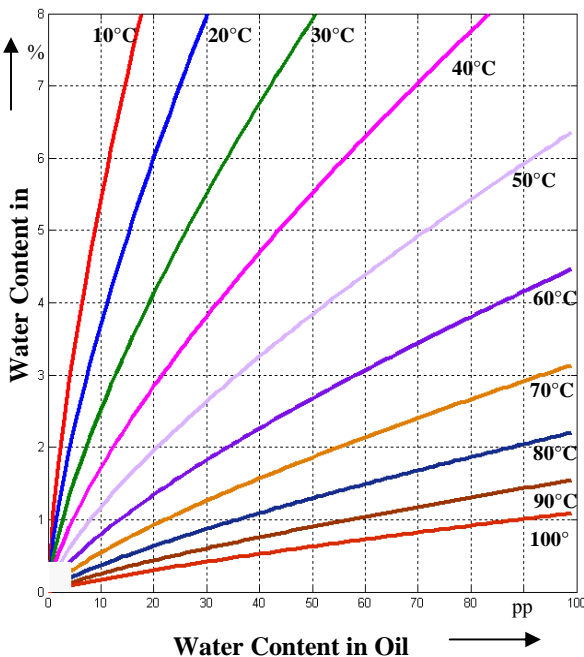

Fig. 3. The equilibrium curves using the mathematical model

Therefore, the water content in paper can be estimated using the equilibrium curves which gives a satisfied results by the estimation. The equilibrium curves can be modelled by using the following empirical equation:

$$W_{CP} = a e^{(bT)} W_{CO}^{(cT+d)} \tag{10}$$

Where a, b, c and d are the constants. This equation fulfils with the equilibrium curves in Fig. 3 and can be used as a mathematical model.

D. Indirect Measurement of WCP

The off-line insulation condition transformer measurements of the dielectric response and analysis of water content in oil paper insulations of power and instrument transformers can be achieved with different methods [13]. Recently, those methods are grouped as: Time domain, Frequency domain, analytical Fourier transform.

III. INSULATION DIELECTRIC RESPONSE

The off-line insulation condition transformer measurements of the dielectric response and analysis of water content in oil paper insulations of power and instrument transformers can be achieved with different methods. Recently, those methods are grouped as: Time domain, Frequency domain, Fourier transform and hybrid method [7].

A. Time Domain Measurements

The time domain model is based on measurements of the polarization and depolarization current "PDC". The (PDC) following a dc voltage step is one way in the time domain to investigate the slow polarization processes [5, 9].

The dielectric of the test object must be cleared or discharged from any charges which can be remaining in before the PDC measurement. The voltage source should be stable and without any ripple and noise in order to detect any small polarization current with sufficient accuracy. The test object is stressed for a long time (e.g., 10000 s) with a dc charging voltage of magnitude U_c .

The polarization current $i_{pol}(t)$ through the test object is measured during this time. The $i_{pol}(t)$ arising from the activation of the polarization process with different time constants corresponds to different insulation materials and to the conductivity of the object, which has been previously carefully discharged. Then the polarization (or absorption, or charging) current $i_{pol}(t)$ through the test object can be expressed by the following equation:

$$i_{pol}(t) = C_o U_c \left[\frac{\sigma_o}{\epsilon_o} + \epsilon_\infty \delta(t) + f(t) \right] \tag{11}$$

where: C_o - the geometrical capacitance of the test object, U_c - the step voltage (charging voltage), σ_o - the DC conductivity of the dielectric material, ϵ_o - the vacuum permittivity, ϵ_∞ - the high frequency component of the permittivity, $\delta(t)$ - the delta

function arising from the suddenly applied step voltage at $t = t_0$, $f(t)$ - the response function of the dielectric material.

After that the voltage is removed and the object is short circuited at $t = t_c$, enabling the measurement of the depolarization current (or discharging, or de-sorption) $i_{\text{dpol}}(t)$ in the opposite direction, without contribution of the conductivity. The polarization current measurement can usually be stopped if the current becomes either stable or very low. According to the superposition principle the sudden reduction of the voltage U_c to zero is regarded as a negative voltage step at time $t = t_c$. Neglecting the second term in equation (10) we get for $t = (t_0 + T_c)$, [5, 14, 15]:

$$i_{\text{dpol}}(t) = -C_o U_c [f(t) - f(t + T_c)] \quad (12)$$

where T_c is the polarization time (charging time) of the test object.

The schematic diagram of the PDC measuring technique is shown in Fig. 4 and the typical nature of these currents due to a step charging voltage U_c in Fig. 5.

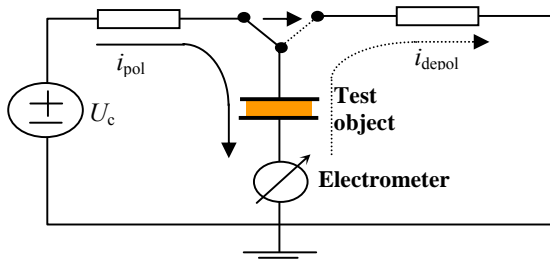

Fig. 4. Principle of test arrangement for the ‘‘PDC’’ measuring technique.

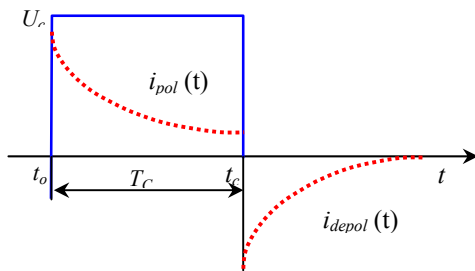

Fig. 5. Principle of polarization and depolarization current (PDC)

The insulation between transformer windings is charged by a dc voltage step of 200 V. A long charging time is required (10,000 s) in order to assess the interfacial polarization and paper condition. The initial time dependence of the polarization and depolarization currents (more than 100 s) is very sensitive to the conductivity of the oil while the moisture content of pressboard influences mainly the shape of the current at longer times [16, 17].

B. Frequency Domain Measurements

The dielectric response can be investigated and measured in

frequency domain by applying an ac sinusoidal voltage $U(\omega)$ to the test object. The object which is impregnated in oil is equivalent to a complex capacitance, and the relation between applied sinusoidal voltage $U(\omega)$ and measured sinusoidal current $I(\omega)$, can be expressed as:

$$\hat{U}(\omega) = \frac{\hat{I}(\omega)}{j\omega C_o \left[\underbrace{\epsilon_\infty + \chi'(\omega)}_{\epsilon'(\omega)} - j \underbrace{\left(\frac{\sigma_o}{\epsilon_o \omega} + \chi''(\omega) \right)}_{\epsilon''(\omega)} \right]} \quad (13)$$

where $\chi(\omega) = \chi'(\omega) - j\chi''(\omega)$ is the Fourier transform of the dielectric response function $f(t)$ and defined as the complex dielectric susceptibility. With $\epsilon(\omega) = \epsilon'(\omega) - j\epsilon''(\omega)$, the loss or dissipation factor $\tan \delta$ in frequency domain can be defined as follows [4, 5, 18]:

$$\tan \delta(\omega) = \frac{\epsilon''(\omega)}{\epsilon'(\omega)} = \frac{\frac{\sigma_o}{\epsilon_o \omega} + \chi''(\omega)}{\epsilon_\infty + \chi'(\omega)} \quad (14)$$

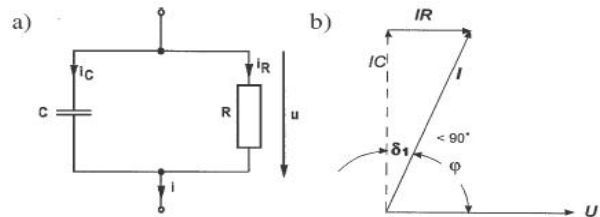

Fig. 6. Equivalent circuit diagram (a) and vector diagram (b) of the dielectric loss factor $\tan \delta$.

C. Fourier transform

The Fourier transform is a well known specific form of analytical transforms of one function into another, which is called the frequency domain representation of a function in the time-domain. The dielectric response function can be transformed from time domain to frequency domain to improve interpretation of the measuring results and to reduce the measuring time duration [19].

The real and imaginary parts of the complex electric capacitance in frequency domain can be calculated as follows according to the polarization and depolarization exponential fitted currents.

$$C'(\omega) = \frac{1}{U_c} \sum_{k=1}^n \frac{C_k \lambda_k}{\lambda_k^2 + \omega^2} + C_\infty \quad (\text{For depolarization}) \quad (15)$$

$$C''(\omega) = \frac{1}{U_c} \sum_{m=1}^n \frac{C_m}{\lambda_m^2 + \omega^2} \quad (\text{For polarization}) \quad (16)$$

D. Hybrid FDS and PC Measurements method

The hybrid method is a combination of the time domain polarization current (PC) measurements and frequency domain spectroscopy (FDS) [5, 20].

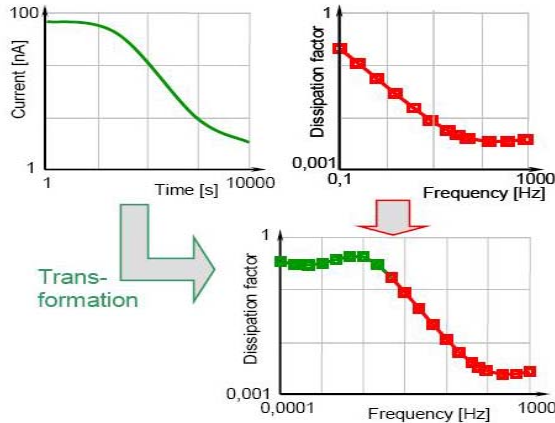

Fig. 7. Hybrid FDS and PC Measurements method

This method reduces drastically the test duration compared to existing techniques. Essentially, time domain measurements can be accomplished in a short time but are limited to low frequencies (typically below 1 Hz). In contrast, frequency domain measurements are feasible for high frequencies as well but take very long time at low frequencies.

The measuring system “Dirana” from Omicron, acquires data in frequency domain from 1 kHz down to 0.1 Hz and in time domain from 0.1 Hz to 100 μHz. For further evaluation the time domain data are transformed to frequency domain. For 1 kHz down to 0.1 mHz it requires about 3 hours to record data from 1 s to 10000 s corresponding to 1 Hz up to 0.1 mHz.

E. Winding Insulation Model

For modelling purposes, it is sufficient to represent the insulation structure by the relative amount of spacers and barriers in the duct. The moisture analysis at first the insulation temperature T from the measured dielectric response $C(f)$ is taken, the corresponding permittivity record $\epsilon_{PB}(f)$ from the extra data base and interpolated data base and the spacer permittivity $\epsilon_{spacer}(f)$. The so called XY-model combines this permittivity record $\epsilon_{PB}(f)$ with the complex oil permittivity $\epsilon_{oil}(f)$. The XY-model allows for the computation of the dielectric response of a linear multi-layer-dielectric, where X represents the ratio of barriers to oil and Y the ratio of spacers to oil [21].

The mathematical representation of this model is given by equation (17).

$$\epsilon(\omega, T)_{duct} = \frac{Y}{\frac{1-x}{\epsilon_{spacer}} + \frac{X}{\epsilon_{barrier}}} + \frac{1-Y}{\frac{1-X}{\epsilon_{oil}} + \frac{X}{\epsilon_{barrier}}} \quad (17)$$

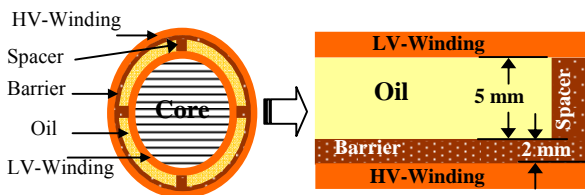

Fig. 8 Illustration of the winding insulation model

IV. CONDITIONS AND SETUP OF THE MEASUREMENTS

Measurements performed in the laboratory of the Schering-Institute, Leibniz University of Hanover, Germany, on a distribution transformer. The temperature effect on the characteristic of the transformer insulation system (oil - paper) was investigated on a 400 V / 10 kV, 100 kVA oil filled distribution transformer, which has been in service for 20 years. It removed from service two years ago and stored in the laboratory at room temperature that guarantees water equilibrium in the insulation. The measured water content 18 ppm at room temperature at the beginning of the measurements.

The transformer was prepared and situated in a special adiabatic room shown in Fig. 9 and it was covered with a thermal cover as a temperature (heat) keepers. As the measurements were carried out off-line it is important to keep the transformer temperature stable during the measurement time of the FDS and PC measurement which is about 3 hours.

The transformer temperature was monitored using temperature sensors placed at different positions on the tank. The low voltage side was short-circuited and the high voltage side connected by an autotransformer to the network, taking into account that the current on the low side will heat the transformer without exceeding the nominal ranges.

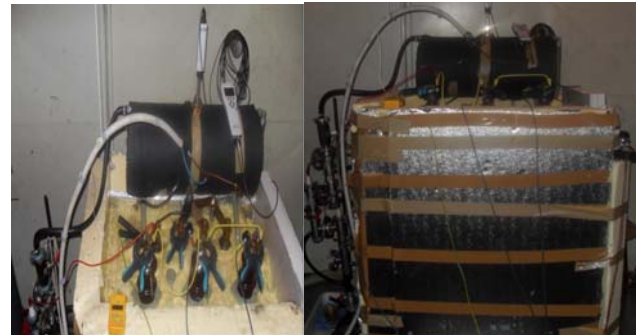

Fig. 9. The transformer measurements.

The temperature adjustment was achieved by autotransformer voltage regulating and a special thermo protection. The measuring system “Dirana” was installed at the transformer. Fig. 10 shows the schematic diagram for the measuring connections. The “Dirana” was connected to the transformer in a two winding connection. The voltage output is coupled with the HV winding, the current input with the LV winding and the guard with the tank.

The temperature inside the transformer and the water content in the oil was measured by “Vaisala (MM70)” system which records on line temperature and moisture.

The preparation and measurements were made during 50 days and the transformer was de-energized before each measurement. Consequently, during the measurements a decrease in the temperature of about 5°C was realized due to the thermal insulation. But the transformer was without cover when it was considered as a normal transformer.

In this situation the temperature decrease by about 15 - 35°C in comparison to starting temperature.

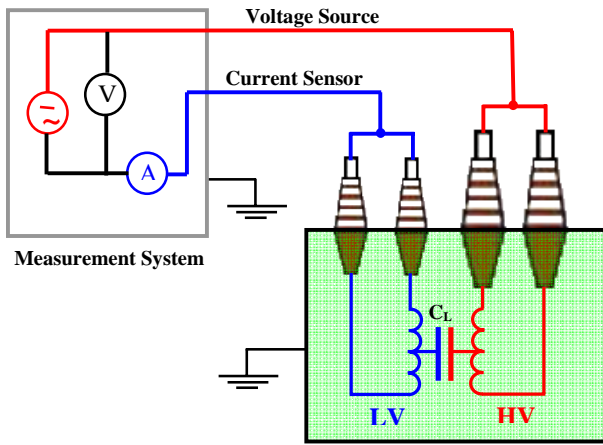

Fig. 10. Schematic diagram for “Dirana” connections.

The water content in the oil of this transformer at 22°C was about 18 ppm. The transformer was for a long time at room temperature under equilibrium condition and the water content in the paper was calculated to about 4.5% refer to Du [4]. To reach the equilibrium conditions for the investigated transformer at desired temperatures it needs time and this time was calculated and given in Table I and these times were considered in the measurements [5, 22].

In addition, for all the measurements the verification of the equilibrium conditions was achieved by means of the “Vaisala” system. The temperature transition conditions are simulated in an indirectly heated test setup, which represents the insulation system of a power transformer.

TABLE I
REQUIRED TIME IN HOURS TO REACH THE EQUILIBRIUM

Water concentration in paper	25°C	50°C	60°C	70°C
3%	675.7	84.3	40.0	19.8
4%	409.8	51.0	24.3	12.0
5%	248.5	31.0	14.7	7.3

A. Measurements Progress and Sequence

The measurements are divided into four main stages as the conditions were changed:

First stage: the thermal cover installed to surround the transformer as in fig. 9 to achieve the equilibrium conditions and to keep the temperature stable during the measuring process without sudden decreases, which is simulating the transformers real operation conditions and situation with a fixed load. The first stage consists of 3 basic measurements cases :at the room temperature 25°C, when the transformer reached 50°C firstly and at 50°C in equilibrium conditions. Note that for every case there was minim 2 measurements to verify the accuracy and avoided the random errors (see Fig.11 measurements 1,2 and 3).

Second stage: The thermal cover still surrounding the

transformer. The second stage consists of 2 basic measurements cases: when the transformer reached the 70°C temperature firstly and at 70°C in equilibrium conditions (see Fig. 11. measurements 4 and 5).

Third stage: The thermal cover still surrounding the transformer. The third stage consists of 2 basic measurements cases: when the transformer temperature down to reach the 60°C firstly and at 60°C in equilibrium conditions (see Fig11. measurements 6 and 7).

After the third stage we where able by hybrid FDS and PC Measurements to define the equilibrium conditions for the temperatures 25 °C, 50 °C, 60 °C and 70 °C .

Fourth stage: the thermal cover was removed to simulate the transformers real operation conditions and when a fault accrues or a normal planed test is carried out the transformer will be disconnected, consequently the temperature will be decreased. Usually transformer working temperature is related to the loading mode and the ambient temperature.

Referring to the standard temperature limits [4, 23], the average winding temperature rise is 65° C above ambient. Therefore the maximum operational temperature in this investigation was chosen 70°C.

This stage is consists of several cases:

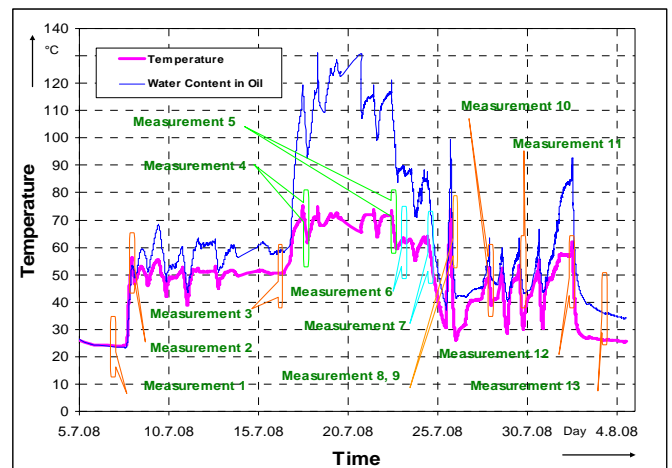

Fig. 11. An illustration for the measurements flow chart progress and sequence

Then the transformer reconnected to the network to be back to the operational temperature 50°C. At 50°C two measurements where performed, the first one immediately after disconnecting, the second one after 1 hour. (See fig. 11. measurements 10 and 11). The transformer reconnected to the network to reach the operational temperature 60 °C. At 60 °C two measurements where performed, the first one immediately after disconnecting, the second one after 30 hours after disconnecting (see fig. 11. measurements 12 and 13). Then the transformer reconnected to the network to be back to the operational temperature 50°C. At 50°C two measurement where performed, the first one immediately after disconnecting, the second one after 1 hour. (see fig. 11.

measurements 10 and 11). The transformer was reconnected to the network to reach the operational temperature 60 °C. At 60 °C two measurements were performed, the first one immediately after disconnecting, the second one after 30 hours after disconnecting (see fig. 11. measurements 12 and 13).

B. First Measurements stage

This stage of measurements concludes the 1st, the 2nd and the 3rd measurements group as shown in Fig. 11. The results of hybrid FDS & PC with tan d are illustrated in Fig. 12.

The dielectric response was measured at the first time when the transformer temperature was 25°C (room temperature). The transformer was connected to the network, when it is reached the 50°C the second measurement was carried out.

The transformer was connected about ten days to reach the equilibrium conditions as it was recommended, see table I [4].

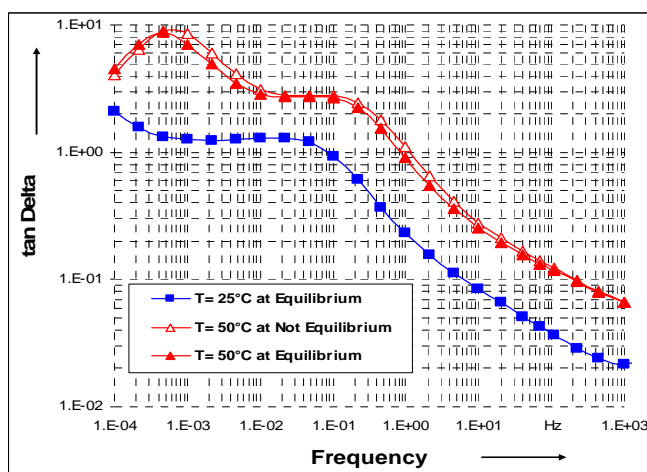

Fig. 12. Hybrid FDS and PC measurements for the equilibrium and non equilibrium conditions (25 °C and 50 °C)

Then the transformer was reconnected to the network to be back to the operational temperature 50°C. At 50°C two measurements were performed, the first one immediately after disconnecting, the second one after 1 hour. (see fig. 11. measurements 10 and 11).

The transformer was reconnected to the network to reach the operational temperature 60 °C. At 60 °C two measurements were performed, the first one immediately after disconnecting, the second one after 30 hours after disconnecting (see fig. 11. measurements 12 and 13). The result of the water content in paper and oil for the first measurements stage are illustrated in Table II.

TABLE II
THE RESULT OF THE WATER CONTENT IN PAPER AND OIL FOR THE FIRST MEASUREMENTS STAGE

Number of measurement	Temperature °C	Water in Oil ppm	Water in Paper %	
			Equilibrium	Omicron
1	25	23.5	5	5.4
2	50	52	4.2	5.2
3	50	58	4	4.9

C. Second Measurements stage

This stage of measurements concludes the 4th and 5th measurements group as shown in Fig. 11.

The results of hybrid FDS & PC with tan δ are illustrated in Fig. 13.

The result has no significant changes between the non equilibrium and the equilibrium conditions for the 70°C. The reason for this case can be understand as the transformer was working for more than ten days at the equilibrium conditions for the 50°C. After so the temperature was increased to the 70°C and the difference between the equilibrium and non equilibrium about 7h according to the table I the measurement was made several times and the results were similar. Water content in oil did not changed significantly and it was about 116 ppm. The only change of tan d was in the frequencies range of 10 to 1 mHz.

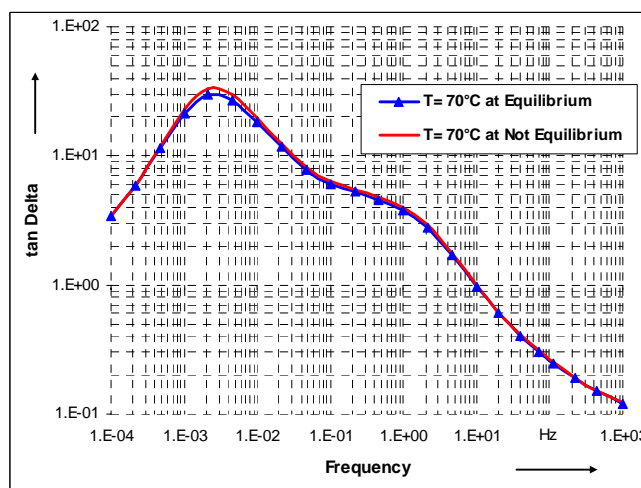

Fig. 13. Measurements in equilibrium not equilibrium at 70°C

D. Third Measurements Stage

This stage of measurements concludes the 6th and 7th measurements group of as shown in Fig. 11. The results of hybrid FDS & PC with tan δ at 60 °C were completed for the equilibrium and non equilibrium conditions.

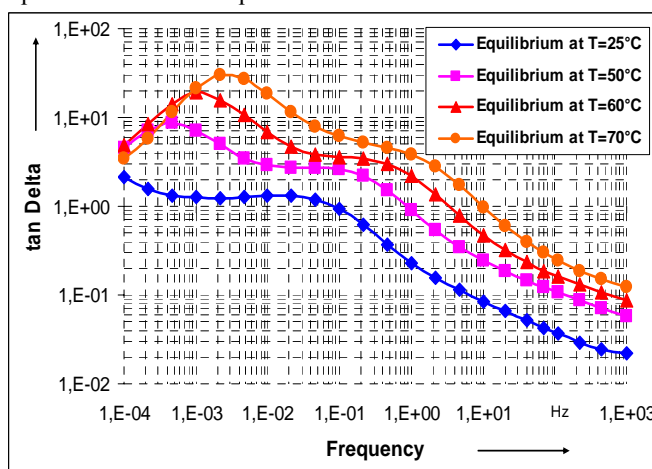

Fig. 14. Hybrid FDS and PC Measurements for the equilibrium conditions (25 °C, 50 °C, 60 °C, 70 °C)

By ending the third stage the basic equilibrium conditions for the temperatures 25 °C, 50 °C, 60 °C and 70 °C has been defined. These results are illustrated in Fig. 14.

E. Fourth Measurements Stage

The first part of this stage consist of the measurements 8 and 9. It was holed at the 70°C immediately after disconnecting from the network and after 3 hours. The results illustrated in Fig. 15 in comparing with the equilibrium conditions at 70°C as a reference.

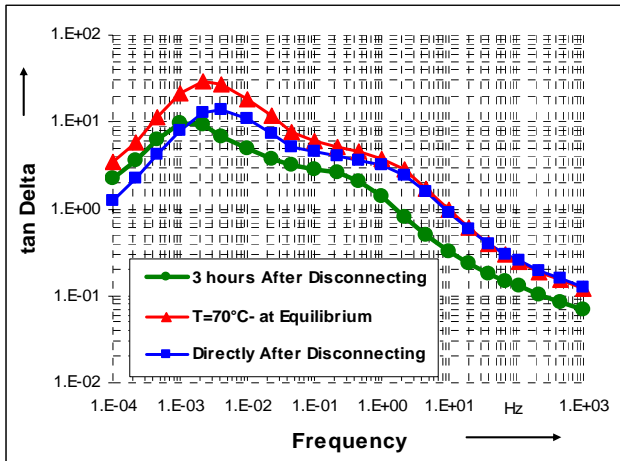

Fig. 15 Measurements in equilibrium at 70°C, direct disconnection and after 3 hours of disconnecting

The immediate measurement shows no changes from the reference at high frequencies, but a remarkable difference at low frequencies. The after 3 hours measurement shows a large difference in tan δ over the complete frequency range. The second part consist of two measurements at 50°C, immediately after disconnecting the 10 measurement and after 1 hour, the 11, as it was shown in Fig. 11. The results illustrated in Fig. 16 (50°C at equilibrium, direct and after 1) in comparing with the equilibrium conditions at 50°C as a reference.

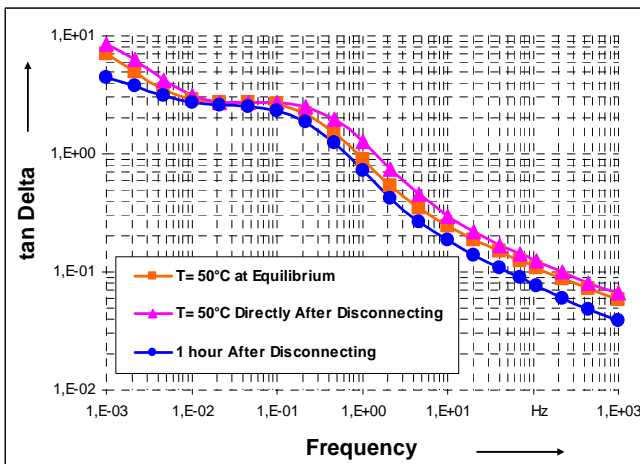

Fig. 16 Measurements in equilibrium at 50°C, directly after disconnection and after one hour of disconnecting

The third part consist of two measurements at 60°C, immediately after disconnecting, after 30 hour, 13 and 14 measurements as shown in Fig. 11. The results are illustrated in Fig. 16 (60°C at equilibrium, Direct and after 3 hours) in comparing with the equilibrium conditions at 60°C as a reference.

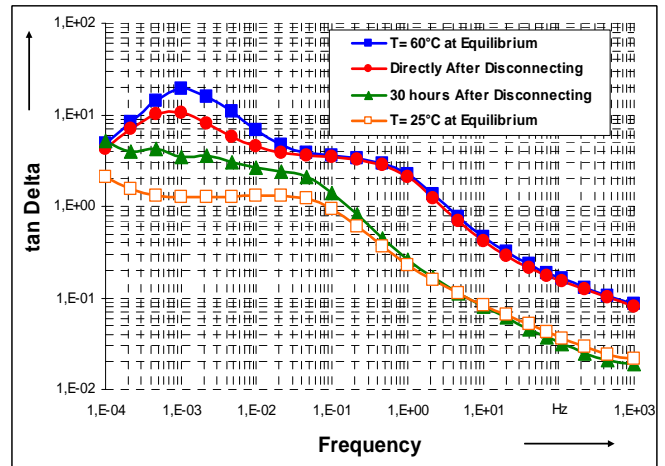

Fig. 17 Measurements in equilibrium at 60°C, directly after disconnection and after 30 hours of disconnecting

Furthermore the measured values after 30 h shows a good agreement with the equilibrium values of 25 °C at high frequencies, but a large deviation at lower frequencies.

F. Analysis Experimental Results

The water content in the oil of this transformer at 22°C was about 18 ppm. The transformer was for a long time at room temperature under equilibrium condition and the water content in the paper was calculated to about 4.5% refer to Du [14]. To reach the equilibrium conditions for the investigated transformer at desired temperatures it needs time and this time was calculated and is given in Table I and these times were considered in the measurements [12]. In addition, for all the measurements the verification of the equilibrium conditions was achieved by means of the “Vaisala” system.

When a transformer has to be tested, it is shall be switched off and only after a period of time the measurements can start. This time may depend on the qualification of the staff which is in charge for the measurements. That means that the transformer parameters changes during this delay time and particularly the temperature and consequently the water content in oil and paper change according to the further information. The illustrated experiments were to emphasize that the time between the transformers are switched off and the start of the measurements is very important and should be kept as short as possible. Naturally, the temperature of a loaded transformer is higher than the environment temperature and the transformer temperature will decrease after switch off. This decrease in temperature cause changes in water content solubility for the insulation oil and paper and should be taken

into account carefully in the interpretation of the measurements. Furthermore, the temperature in a transformer does not remain constant during long periods of time due to continuous variations of load and ambient temperature.

The results of non-equilibrium at 25°C are close to the results at equilibrium at 50°C in the middle frequency range near to 0.01 Hz. The reason the influence of temperature on the water content in oil and paper. Oil conductivity has the major influence on the $\tan \delta$ at the middle frequency range [11], and this cause the difference of the measured values at the equilibrium and non equilibrium condition as shown in Fig. 12.

In the low frequency range (less than 1 mHz) the paper conductivity has the major influence on the $\tan \delta$ and this causes the difference between measured values at equilibrium and non equilibrium condition. The water content in oil at non equilibrium conditions is higher compared to equilibrium.

At 70°C the transformer was disconnected and immediately the measurement was started, but the measurement takes about three hours and the temperature decreases to about 35°C Therefore the agreement in the high frequency range between equilibrium and measurement immediately after disconnecting the transformer are very good. As longer the time as larger is the deviation between the two curves in Fig. 11, which means that lower temperature leads to a lower $\tan \delta$.

The next measurement was started immediately after the end of the first measurement, which is about three hours after disconnecting the transformer from then network. The temperature is now 35°C and this will influence remarkably the measuring results of the $\tan \delta$.

In this equilibrium condition the PDC and FDS measurements were performed. After this measurement the high voltage side transformer was connected to the electrical network through an autotransformer and the low voltage side was short circuited. The transformer was warmed with setup of short circuit current and temperature was controlled until 70°C.

V. MONITORING THE WATER CONTENT IN PAPER AND OIL

The on-line monitoring the water content in paper and oil was achieved by on-line monitoring VAISALA MM70. Which measure the water activity (aw) and by equation (3) the water content was calculated. The data were stored consensually and without any discrete during energize and de-energize time, in other words, during preparation and measurement time for about one month. Omicron "Dirana" monitoring system calculated the off-line monitoring for the water content in oil on the base of hybrid FDS & PC measurements. Which has a data base system for comparing and evaluating the measured values and it makes a reliable moisture analysis of onsite measurements bases data pool constitutes of measurements on new pressboard at various temperatures, moisture contents and oil. Therefore the measured and calculated water content in paper has different values between the Omicron system and equilibrium craves as shown in Fig. 18.

Where Fig.18 illustrate the on-line monitoring the water content in paper and oil change during the measurements time for one month. Also the table III shows a detailed result of water content for a number of the measurements comparing the water in paper with its equilibrium values.

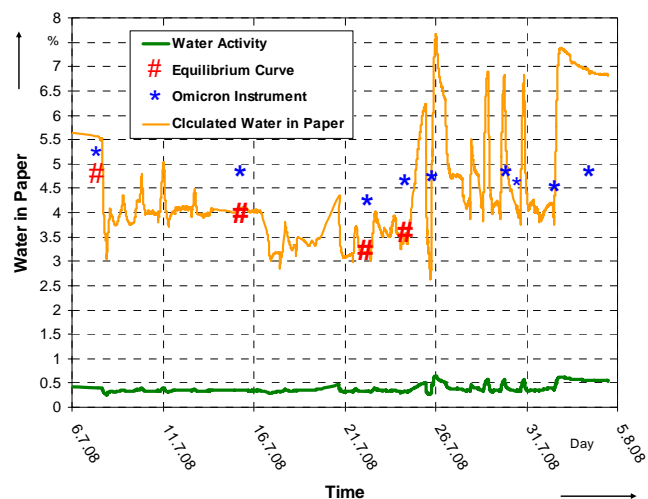

Fig. 18 On-line monitoring the water content in paper and oil change during the measurements time

The result reflects the relation between the equilibrium conditions and non-equilibrium conditions by defining a margin of difference or permissibility for different operational temperature. This can be a guide recommendation for engineers before providing such measurements. More over using this device or sensor can be online and without any disconnecting for the transformer from the network. Normally the transformers are working on a routine load curves and in equilibrium conditions or near to it. Importance of the result in Fig. 18 is that when the transformer in equilibrium conditions or near to it the result are identical for the water content in paper. But when the transformer is not in equilibrium conditions the water content in paper can be taken as the average of the results. This can be clearly shown in Fig. 18 for the measurements in about 50 days. This has big economical and reliable effects on the operational condition of the electrical system. There was no need to plane disconnections to provide schedule testes. This means the measurements are on-line and reflect the real condition of the transformer, no change in the oil temperature during the measurement or after disconnection. The measuring system (Vaisala) relatively not expensive compared with other systems.

TABLE III
RESULTS OF THE WATER CONTENT IN PAPER AND OIL
FOR THE MEASUREMENTS EQUILIBRIUM CONDITION

Number of measurement	Temperature °C	Water in Oil ppm	Water in Paper %	
			Equilibrium	Omicron
1	25	23.5	5	5.4
3	50	58	4	4.9
5	70	116	3.2	4.3
7	60	83	3.5	4.7

The influence of temperature is very specific and depends on water content [4]. Therefore, despite an abundance of experimental data, it has been impossible, until now, to generalize and to mathematically describe, for engineering use, the influence of this most important general parameter of liquid dielectrics. Therefore it can be only achieved by empirical formulas and relations.

VI. CONCLUSION

The main framework of this article has been performed on the dielectric response and water content measurements. The basis of practical operational experiences with monitoring systems deployed in the field of evaluating the dielectric response of transformer in different equilibrium conditions and temperatures. Using the Hybrid FDS & PC method is drastically reduces the test duration compared to existing techniques. The obtained results show that temperature variation and the sharing of moisture between the oil and paper affect the dielectric response measurements. The results show also, that temperature variation has the big influence on the dielectric response than the water in oil and paper in the high temperature measurements. Overall, investigations have shown that the extremely influence of the time between disconnecting the transformer and beginning the measurements on the results of the FDS & PC measurements. And on the analysis of water content in oil- paper insulations of transformers was shown. The experimental results emphasized the online monitoring for water content in paper measurements, as accurate methods without disconnection. This aim can be realized by the means oil water content on line monitoring and the obtained equilibrium curves as it was shown in this article. The experimental investigations of the electrical strength of transformer oil during moisture non-equilibrium are presented.

ACKNOWLEDGMENT

Dr. Jalal Abdallah is very grateful for the Schering-Institute/Germany, the DFG and Tafila Technical University for financial and scientific support in this research.

REFERENCES

- [1] P. J. Griffin and J. Christie, "Effects of Water and Benzotriazole on Electrostatics Charge Generation in Mineral Oil/Cellulose Systems", Proceedings: Static Electrification in Power Transformers, EPRI TR-102480, Project 1499-99, June 1993.
- [2] O. Rouse, "Mineral Insulating Oil in Transformers", Electrical Insulation Magazine, Vol. 14, No. 3, pp. 6-16, May/June 1998.
- [3] V. G. Arakelian, I. Fofana "Water in Oil-Filled High-Voltage Equipment Part II: Water Content as Physicochemical Tools for Insulation Condition Diagnostic", IEEE Trans. Dielectr. Electr. Insul. Vol. 23, No. 5, September/October 2007.
- [4] IEEE Guide for Loading Mineral-Oil Immersed Power Transformers, IEEE Standard C57.91, Institute of Electrical and Electronic Engineers, New York NY, 1995.
- [5] A. Setayeshmehr, J. Abdallah, A. Akbari, H. Borsi and E. Gockenbach, "Evaluation of water exchange between oil and paper in transformer under operating condition", the 16th International Symposium on High Voltage Engineering Johannesburg, ISH 2009.

- [6] Y. Du, M. Zahn, B.C. Lesieutre and A.V. Marnishev and S.R. Lindgren "Moisture Equilibrium in Transformer paper-oil systems", IEEE Electr. Insul. Mag., Vol. 15, No. 1, 1999.
- [7] T. K. Saha, "Review of Modern Diagnostic Techniques for Assessing Insulation Condition in Aged Transformers", IEEE Trans. Dielectr. Electr. Insul. Vol. 10, pp. 903-917, 2003.
- [8] W.S. Zaengl, "Dielectric Spectroscopy in Time and Frequency Domain for HV Power Equipment, Part I: Theoretical Considerations", IEEE Elec. Insul Mag., Vol. 19, No. 5, pp. 5-19, 2003.
- [9] W.S. Zaengl, "Application of Dielectric Spectroscopy in Time and Frequency Domain for HV Power Equipment", IEEE Elec. Insul. Mag., Vol. 19, No. 6, pp. 9-22, 2003.
- [10] "Relative Humidity," Britannica Online 1994-1997 Encyclopedia Britannica, Inc. URL: <http://www.britannica.com/>.
- [11] Y. Du, A. V. Marnishev, B. C. Lesieutre, M. Zahn, and S. H. Kang, "Moisture solubility for differently conditioned transformer oils," IEEE Trans. Dielect. Electr. Insulation, vol. 8, pp. 805-811, Oct. 2001.
- [12] B. Garcia, J. C. Burgos, "A Moisture-in-Oil Model for Power Transformer Monitoring- Part I: Theoretical Foundation", IEEE Trans. Power Delivery, Vol. 20, NO. 2, pp. 1417-1422, 2005.
- [13] B. Pahlavanpour, M. Martins, D. Eklund, "Study of moisture equilibrium in oil-paper system with temperature variation", 7th International Conference on Properties and Application of Dielectric Materials, Nagoya, Japan, 2003.
- [14] P. J. Griffin, "Water in Transformers-so what!" in National Grid Condition Monitoring Conf., May 1996.
- [15] A. Seytashmehr, I. Fofana, C. Eichler, A. Akbari, H. Borsi and E. Gockenbach, "Dielectric Spectroscopic Measurements on Transformer Oil- paper Insulation under Controlled Laboratory Conditions", IEEE Trans. on Dielectr. and Elec. Insul. Vol. 15, pp. 1100-1111, 2008.
- [16] T. K. Saha and P. Purkait, "Effects of Temperature on Time-Domain Dielectric Diagnostics of Transformers", Australasian Universities Power Engineering Conf., Christchurch, New Zealand, 2003.
- [17] S. Zaengl, "Dielectric Spectroscopy in Time and Frequency Domain for HV Power Equipment, Part I: Theoretical Considerations", IEEE Elec. Insul Magazine, Vol. 19 No. 5, pp. 5-19 September/October 2003.
- [18] A. B. Supatra, "The Latest On-Site Non-Destructive Technique for Insulation Analysis of Electrical Power Apparatus", Weidmann-ACTI Annual Technical Conference, Sacramento, USA, 2004.
- [19] A. Setayeshmehr, C. Eichler, A. Akbari, H. Borsi and E. Gockenbach, "Condition Evaluation of Oil-Pressboard Insulation by Fourier Transform Of Time Domain Dielectric Response", NORDIS 2007.
- [20] A. Akbari, A. Setayeshmehr, M. Farahani, H. Borsi and E. Gockenbach, "A Software Technique for Transforming Dielectric Data from Time Domain to Frequency Domain for Insulation Diagnosis of Power Transformers", 15th International Symposium on High-Voltage Engineering (ISH), Ljubljana, Slovenia, 2007.
- [21] H. Borsi, E. Gockenbach, M. Krueger, "Method and Device for Measuring a Dielectric Response of an Electrical Insulation System", European Patent EP 1729139.
- [22] M. Koch, M. Krueger, "A Fast and Reliable Dielectric Diagnostic Method to Determine Moisture in Power Transformers" International Conference on Condition Monitoring and Diagnosis, Beijing, China, April, 2008.
- [23] U. Gafvert, G. Frimpong, and J. Fuhr: "Modelling of dielectric measurements on power transformers", Proc. 37th Session "Large High Voltage Electric Systems" (CIGRE), paper 103, Paris, France, 1998

Jalal M. Abdallah Was born in Amman, Jordan. He received his M.S. 1994 and Ph.D. 1998 in electrical engineering from Vinita Stat Technical University, Ukraine.

Since 1998 He joint Al Balqa applied university. And in 2005 he joint Tafila Technical University where he is currently an Associate Professor at the electrical Engineering Department.

Dr. Jalal main research interests are power system analysis, monitoring, and diagnostic of high-voltage power transformers.