

Discrete Vector Control for Induction Motor Drives with the Rotor Time Constant Update

A.Larabi, M.S. Boucherit

Abstract—In this paper, we investigated vector control of an induction machine taking into account discretization problems of the command. In the purpose to show how to include in a discrete model of this current control and with rotor time constant update. The results of simulation obtained are very satisfaisant. That was possible thanks to the good choice of the values of the parameters of the regulators used which shows, the founded good of the method used, for the choice of the parameters of the discrete regulators. The simulation results are presented at the end of this paper.

Keywords—Induction Motor - Discrete vector control – PI Regulator - Transformation of Park - PWM

I. INTRODUCTION

IN our case ,one is interested in the asynchronous cage machine. On the level of the converter, one chose a converter of the inverter type of tension to modulation PWM, because this type of inverter is well appropriate for the machines of small power and has a great simplicity in terms of modeling. Indeed, the frequency of modulation can be sufficiently high compared to the frequency of the tensions which are applied to the machines. In this case, one can admit that the converter behaves like an ideal amplifier. The influence of its modulation on the behavior of the command can be neglected . Our aim in this work is the vectorial control command. There are numerous methods of control for the machines with AC current, which are different mainly by the ways in which one carries out the order of the currents.Among these methods, we chose the one which uses the vectorial control elaborated on the Park model of the machine.The advantage of this method is that it makes it possible to distinguish within the currents of the machine, a couple's producing component and a flux's producing component.Using appropriate decouplings , the electromechanical behavior of the machines with AC current can be made similar, with regard to the ordering of position and speed, with that of a machine with D.C current. In case where one must use processor whose computing power is limited or in the case where frequency PWM must be weak, the discretization problems on the level of the regulation of the currents must be considered. In addition,the ordering of the machines with AC current requires decouplings of currents which are composed of non-linear terms.

The imperfection of these decouplings due to the discretization brings also a considerable influence on the performances of the vectorial control command,which are affected . The block diagram of the figure (4) is very simple and similar to the one of a D.C. current machine, owing to the fact that we considered a constant flux [3],[4]. As for as regulators are concerned, they are used in their discrete form .The calculation of the regulator's parameters has been carried at using software based on the roots places taking into account the effects of discretization [2]. The choice of the parameters of the regulator allows us a good stability as well as a good regulation of the currents. However, studies of literature, the PI controllers are highly dependent on machine parameters, especially the rotor time constant (Tr). A variation of this parameter will result in performance degradation of adjustment, especially when the machine is loaded [5,6,7,8,9]. Considering this major inconvenience, a solution is obtained it using the command with a constant flux because of its simplicity of implementation (figure.4) with the rotor time constant update.

II. MODELLING OF THE INDUCTION MACHINE

To study the vectorial ordering of the asynchronous machine, generally we apply the stator variables as well as the rotor variables of the transformation of Park using :

- For the stator sizes an angle θ , is arbitrary.

-For the rotor sizes, an angle $\theta - p\theta_m$ where θ_m is the rotor position and p represents the number of poles pairs of the machine.

While posing: $\omega = \theta'$ et $\omega_{sr} = \theta' - p\theta'_m$

We get the following equations :

$$\begin{aligned} \frac{d\psi_{sd}}{dt} &= \omega \psi_{sq} - R_S i_{sd} + V_d \\ \frac{d\psi_{sq}}{dt} &= -\omega \psi_{sd} - R_S i_{sq} + V_q \\ \frac{d\psi_{rd}}{dt} &= \omega_{sr} \psi_{rq} - R_r i_{rd} \\ \frac{d\psi_{rq}}{dt} &= -\omega_{sr} \psi_{rd} - R_r i_{rq} \end{aligned} \quad (1)$$

with

$$\begin{aligned} \psi_{sd} &= L_s i_{sd} + M i_{rd} \\ \psi_{sq} &= L_s i_{sq} + M i_{rq} \\ \psi_{rd} &= M i_{sd} + L_r i_{rd} \\ \psi_{rq} &= M i_{sq} + L_r i_{rq} \end{aligned}$$

The stator currents and tensions of the machine's Park model are connected to the currents and stator tensions of the three-phase system by the following transformation:

$$\begin{bmatrix} V_a \\ V_b \\ V_c \end{bmatrix} = \sqrt{\frac{2}{3}} \begin{bmatrix} \cos\theta & -\sin\theta \\ \cos(\theta - \frac{2\pi}{3}) & -\sin(\theta - \frac{2\pi}{3}) \\ \cos(\theta - \frac{4\pi}{3}) & -\sin(\theta - \frac{4\pi}{3}) \end{bmatrix} \begin{bmatrix} V_d \\ V_q \end{bmatrix} \quad (2)$$

III. STRATEGY OF CONTROL

The use of Park referentiel is used to simplify the complex model of the asynchronous machine. An approach often used , is to put the axis "d" of the Park referentiel as the axis of rotor flux, forcing the variable θ to have a value such as ψ_{rq} equal zero. Thus,we can put in evidence, that in accordance with the system of equations of the induction machine, the rotor flux reduced to its single component "d" could be controlled by the current i_{ds} and the couples by the current i_{qs} . If we compensate the coupling terms between the axes "d" and "q":

- the tension V_{ds} allows to command the current i_{ds} , thus the flux.
- the tension V_{qs} allows to order the current i_{qs} , thus the couple.

After arrangement, the machine equations become:
 $\psi_{dr} = \psi_r$, $\psi_{qr} = 0$

$$\begin{aligned} \sigma L_s \frac{di_{ds}}{dt} + i_{ds} &= \frac{V_{dsT}}{R_s} + \sigma L_s \omega_s \frac{T_s(1-\sigma)}{M} \frac{d\psi_r}{dt} \\ \sigma L_s \frac{di_{qs}}{dt} + i_{qs} &= \frac{V_{qsT}}{R_s} + \sigma L_s \omega_s \frac{T_s(1-\sigma)}{M} \psi_r \\ T_r \frac{d\psi_r}{dt} + \psi_r &= M i_{ds} \\ \omega_{sr} &= \frac{M i_{qs}}{T_r \psi_r} , \quad T = \frac{PM}{L_r} \psi_r i_{qs} \end{aligned} \quad (3)$$

In these equations:

- i_{ds} and i_{qs} , V_{ds} and V_{qs} are respectively the d and q axes stator currents and voltages,
- ψ_r is the rotor flux,
- ω_s is the reference frame angular electrical speed:
 $\omega_s = \theta_s$,
- ω_{sr} is the difference between the angular speed of the reference frame and the electrical speed ω of the rotor (the

electrical speed of the rotor is equal to p times its mechanical speed ω_m , p being the pole pairs number).

- T_s and T_r are respectively the stator and rotor d and q windings time constants,
- σ is the leakage coefficient of the machine,
- M is the mutual inductance between rotor and stator dq windings,
- L_r is the rotor dq windings inductance,
- R_s and R_r are respectively the stator and rotor dq windings resistances,
- T_e is the electromagnetic torque.

By introducing the equation (1.c) in (1.a) we obtain the following equations:

$$\begin{aligned} \sigma L_s \frac{di_{ds}}{dt} + R_s i_{ds} &= V_{dsT} + \sigma L_s \omega_s \frac{T_s(1-\sigma)}{T_r} (i_{ds} - \frac{\psi_r}{M}) \\ \sigma L_s \frac{di_{qs}}{dt} + R_s i_{qs} &= V_{qsT} + \sigma L_s \omega_s \frac{T_s(1-\sigma)}{M} \psi_r \\ T_r \frac{d\psi_r}{dt} + \psi_r &= M i_{ds} , \quad \omega_{sr} = \frac{M i_{qs}}{T_r \psi_r} , \quad T_e = \frac{PM}{L_r} \psi_r i_{qs} \end{aligned} \quad (4)$$

In the previous equations the components of the two axes d-q are coupled, their decoupling is possible by the introduction of two new variables: V_{ds} , V_{qs}

$$\begin{aligned} V_{ds} &= \sigma L_s \frac{di_{ds}}{dt} + R_s i_{ds} \\ V_{qs} &= \sigma L_s \frac{di_{qs}}{dt} + R_s i_{qs} \end{aligned}$$

Thus

$$\begin{aligned} V_{dsT} &= V_{ds} + V'_{ds} \\ V_{qsT} &= V_{qs} + V'_{qs} \end{aligned} \quad (5)$$

With V_{ds} et V_{qs} are the outputs of the currents regulators

V'_{ds} et V'_{qs} Terms of decoupling

Thus we distinguish two types of commands one is called complete command, the other simplified: (terms of complete decoupling, terms of simplified decoupling)

$$\begin{aligned} V_{ds'} &= -\sigma L_s \omega_s i_{qs} + \frac{L_s(1-\sigma)}{T_r} (i_{ds} - \frac{\psi_r}{M}) \\ V_{qs'} &= -\omega_s [\sigma L_s i_{ds} - L_s \frac{(1-\sigma)}{M} \psi_r] \end{aligned} \quad (6)$$

Following the studies already done, we noted that, the order using a loop of flux does not make it possible to increase the dynamics performances of the command; it requires the use of the flux regulator adds an additional time-constant, thus generates a reduction in the dynamic performances of the command. To carry out raised performances, structure of the ideal and simple command is the order with constant flux command in open loop and the terms of decoupling calculated with the values of reference. In the case one considers flux: $\psi_r = \psi_{ref} = \psi_{dr}$ we obtain the equations of following simplified (command) thus:

$$\begin{aligned} \psi_r &= \psi_{ref} & V_{ds'} &= -\sigma L_s i_{qsref} \omega_s \\ i_{dsref} &= \frac{\psi_{ref}}{M} & V_{qs'} &= \omega_s \frac{L_s}{M} \psi_{ref} \end{aligned} \quad (7)$$

The block diagram of figure (4) is very simple, similar to the case of a machine with D.C. current, owing to the fact that we considered ψ_r constant. The regulators have been used in their discrete form as well as the calculation of θ . As regard the calculation of Ki and Kp of the regulators, we used a software based on the roots places which takes account the discretization effects. The choice of the regulators parameters allows us a good stability as well as a good regulation of the currents. We will study as regard the influence of the reverse transformation of Park on the performances of the considered order.

IV DISCRETIZATION OF THE COMMAND

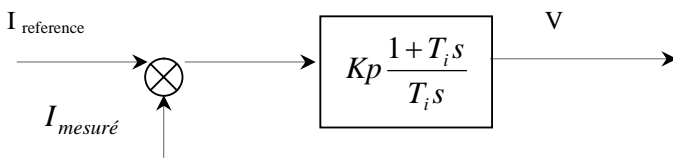

Fig.1 Regulator of current

$$V = K_p (I_{réf} - I_{mes}) + \frac{K_p}{T_i} \int (I_{réf} - I_{mes}) dt$$

On the axis «D»

$$\begin{aligned} V_{ds} &= K_p (I_{dsréf} - I_{dsmes}) + \frac{K_p}{T_{id}} \cdot sum_d(k+1) \\ \begin{cases} V_{dsT} &= K_p (I_{dsréf} - I_{dsmes}) + \frac{K_p}{T_{id}} \cdot sum_d(k+1) + V_{ds} \\ sum_d(k+1) &= sum_d(k) + (I_{dsréf} - I_{dsmes}) \Delta t \end{cases} \end{aligned} \quad (8)$$

On the ' axis «Q»

$$\begin{aligned} V_{qs} &= K_p (I_{qsref} - I_{qsmes}) + \frac{K_p}{T_{iq}} \cdot sum_q(k+1) \\ \begin{cases} V_{qsT} &= K_p (I_{qsref} - I_{qsmes}) + \frac{K_p}{T_{iq}} \cdot sum_q(k+1) + V_{qs} \\ sum_q(k+1) &= sum_q(k) + (I_{qsref} - I_{qsmes}) \Delta t \end{cases} \end{aligned} \quad (9)$$

A. Principle of the method of study of the problems of discretization

The method that we go used is based on the use of the places of roots and is limited to the linear case. The control device of the asynchronous machine comprises two parts: the part continues which is described by the equations of state of the machine and the digital part which is represented by the order. A blocker of order zero is put between these two parts so that the orders applied to the machine are maintained constant for one period of sampling.

B. Modelling with taking into account of the influence of modulation PWM

Because of the complexity of the model of the asynchronous machine, we consider only his electric part. By combining the equations of the machine, one obtains the vector equation of state of this part in matrices form:

$$\dot{X} = A_c X + B_c U \quad (10)$$

$$\begin{aligned} X &= [i_{ds} \quad i_{qs} \quad \psi_{rd} \quad \psi_{rq}]^T ; \quad U = [U_{sd} \quad U_{sq}]^T \\ A_c &= \begin{bmatrix} \frac{R_r + \frac{M^2 R_r}{L_r^2}}{\sigma L_s} & \omega_s & \frac{M R_r}{\sigma L_s L_r^2} & \frac{M B_m}{\sigma L_s L_r} \\ -\omega_s & \frac{R_r + \frac{M^2 R_r}{L_r^2}}{\sigma L_s} & \frac{M B_m}{\sigma L_s L_r} & \frac{M R_r}{\sigma L_s L_r^2} \\ \frac{M R_r}{L_r} & 0 & \frac{R_r}{L_r} & \omega_s - P \omega_m \\ 0 & \frac{M R_r}{L_r} & -(\omega_s - P \omega_m) & \frac{R_r}{L_r} \end{bmatrix} \\ B_c &= \begin{bmatrix} \frac{1}{\sigma L_s} & 0 & 0 & 0 \\ 0 & \frac{1}{\sigma L_s} & 0 & 0 \end{bmatrix}^T \end{aligned}$$

To obtain the discrete model of the total system, one must discretize the model of the continuous part (model of the machine) and to then combine it with the part command.

The discretization of equation (10) is obtained by establishing a relation between the variables at two moments of sequential sampling.

The variables at the moment's k and k+1 are connected by the following equation:

$$X(k+1) = e^{A_c h} X(k) + \int_0^h e^{A_c t} B_c U(k) dt$$

While posing:

$$\Phi = e^{A_c h} \quad \text{et} \quad \Gamma = \int_0^h e^{A_c t} B_c dt$$

$$X(k+1) = \Phi X(k) + \Gamma U(k) \tag{11}$$

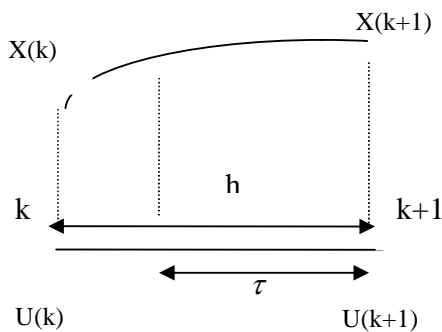

Fig.2

For the part orders, one considers the case where regulators PI are used. The numerical control is represented by the following discrete equation:

$$\begin{bmatrix} U(k+1) \\ S(k+1) \end{bmatrix} = F_1 X(k) + F_2 S(k) + G R(k) \tag{12}$$

Avec
$$S = \begin{bmatrix} Sumd \\ Sumq \end{bmatrix}, \quad R = \begin{bmatrix} i_{dsref} \\ i_{qsref} \end{bmatrix}$$

The matrix F1 represents the action of regulation and of decoupling, the matrix F2 represents the integral action of the regulators for the U(k) command. G is the matrix of entry which represents the connection between the order and the variables of references R(k). S(k) represents the variables of integrators of the regulators. If the regulators are of the type P, we have F2 = 0.

$$F_1 = \begin{bmatrix} -K_d + \frac{K_d}{T_d} h + \varepsilon_1 \left(\frac{L_s}{T_r}\right)(1-\sigma) & -\varepsilon_1 \sigma L_s \omega_s & -\frac{L_s}{T_r} \left(\frac{1-\sigma}{M}\right) & 0 \\ \varepsilon_1 \sigma L_s \omega_s & -K_q + \frac{K_q}{T_q} h & \omega_s L_s \left(\frac{1-\sigma}{M}\right) & 0 \\ -h & 0 & 0 & 0 \\ 0 & -h & 0 & 0 \end{bmatrix}$$

$$F_2 = \begin{bmatrix} \frac{K_d}{T_d} & 0 \\ 0 & \frac{K_q}{T_q} \\ 1 & 0 \\ 0 & 1 \end{bmatrix}$$

$$G = \begin{bmatrix} K_d + \frac{K_d}{T_d} h + \varepsilon_2 \left(\frac{L_s}{T_r}\right)(1-\sigma) & \varepsilon_2 \sigma L_s \omega_s \\ \varepsilon_2 \sigma L_s \omega_s & K_q + \frac{K_q}{T_q} h \\ h & 0 \\ 0 & h \end{bmatrix}$$

$$\begin{cases} \varepsilon_1 = 1 \\ \varepsilon_2 = 0 \end{cases} \quad \text{Decoupling with measured currents}$$

$$\begin{cases} \varepsilon_1 = 0 \\ \varepsilon_2 = 1 \end{cases} \quad \text{Decoupling with currents of reference}$$

To represent a general case, one rewrites the equation (12) while introducing \dot{X} which can be different from the vector of variable of state X

$$\begin{bmatrix} U(k+1) \\ S(k+1) \end{bmatrix} = F_1 \dot{X}(k) + F_2 S(k) + G R(k) \tag{13}$$

As the model to be established must be according to the variables of state X(K), it is necessary to replace \dot{X} by X. En refer to figure (2), one obtains the relation enters and

$$\dot{X}(k+1) = e^{A_c h - \tau} X(k) + \int_0^{h-\tau} e^{A_c t} B_c dt U(k)$$

When taking into account the PWM:

$$B_c = \begin{bmatrix} \cos \omega t & \sin \omega t \\ -\cos \omega t & \cos \omega t \end{bmatrix} B_C$$

$$\Phi_\tau = e^{A_c (h-\tau)}$$

$$\Gamma_\tau = \int_0^{h-\tau} e^{A_c (h-\tau-t)} \begin{bmatrix} \cos \omega t & \sin \omega t \\ -\sin \omega t & \cos \omega t \end{bmatrix} dt B_C$$

Combination of equations (11) (13) gives the following discrete model:

$$\begin{bmatrix} X(k+1) \\ U(k+1) \\ S(k+1) \end{bmatrix} = \begin{bmatrix} \Phi & \Gamma & 0 \\ F_1\Phi_\tau & F_1\Gamma_\tau & F_2 \end{bmatrix} \begin{bmatrix} X(k) \\ U(k) \\ S(k) \end{bmatrix} + GR(k) \quad (14)$$

The discrete matrix of state is thus:

$$A_d = \begin{bmatrix} \Phi & \Gamma & 0 \\ F_1\Phi_\tau & F_1\Gamma_\tau & F_2 \end{bmatrix}$$

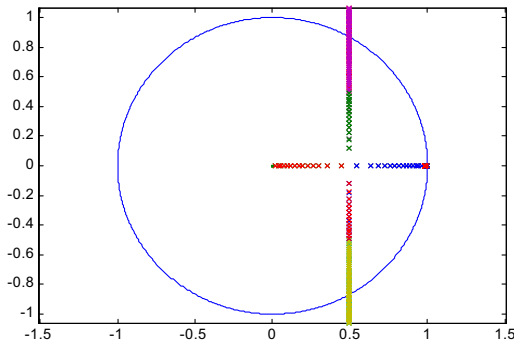

Fig.3 Places of roots according to Kd and Kq.
Without taking account of the PWM

The best results are obtained as kd and kq corresponds to places of roots are on the positive part of the real axis. The response time decreases when the roots approach the origin.

V ESTIMATE OF ROTOR RESISTANCE

To estimate resistance of the rotor we used a method which makes it possible to calculate the latter in function to flux (real, reference) and of the electromagnetic torque (real, reference) [5,6]. To clarify the relation which binds the electromagnetic torque and rotor flux to the variations of the parameters of the machine we let us proceed as follows:

$$\begin{aligned} L_r &= K_l L_r^* \\ R_r &= K_r R_r^* \end{aligned} \quad (15)$$

L_r^*, R_r^* Values used in the command.

The actual value of the rotor time-constant:

$$T_r = \frac{K_l}{K_r} T_r^* = K T_r^* \quad (16)$$

The block of decoupling imposes on the command of the inverter the sizes V_{ds} , V_{qs} and ω_{sr} . In permanent mode we have:

$$\begin{aligned} C_e^* &= \frac{PM^*}{L_r^*} \varphi_r i_{qs} = \frac{PM^{*2}}{L_r^*} i_{ds} i_{qs} \\ \omega_{sr}^* &= \frac{1}{T_r^*} \frac{i_{qs}}{i_{ds}} \\ \varphi_r^* &= M^* i_{ds} \end{aligned} \quad (17)$$

From the equations of Park of the machine we draw the components direct and in squaring from rotor flux and the real torque of the machine with permanent rate:

$$\varphi_{dr} = M \frac{i_{ds} + \omega_{sr} T_r i_{qs}}{1 + (\omega_{sr} T_r)^2}$$

$$\varphi_{qr} = M \frac{i_{qs} - \omega_{sr} T_r i_{ds}}{1 + (\omega_{sr} T_r)^2}$$

$$C_e = P \frac{K_l^2}{K_r} \frac{M^{*2}}{L_r^*} i_{ds} i_{qs} \frac{1 + \left(\frac{i_{qs}}{i_{ds}}\right)^2}{1 + \left(K \frac{i_{qs}}{i_{ds}}\right)^2} \quad (18)$$

$$\varphi_r = K_l M^* i_{ds} \sqrt{\frac{1 + \left(\frac{i_{qs}}{i_{ds}}\right)^2}{1 + \left(K \frac{i_{qs}}{i_{ds}}\right)^2}}$$

The rappsorts of the real couple and flux on the estimated values are:

$$\frac{\varphi_r}{\varphi_r^*} = K_l \sqrt{\frac{1 + \left(\frac{i_{qs}}{i_{ds}}\right)^2}{1 + \left(K \frac{i_{qs}}{i_{ds}}\right)^2}}$$

$$\frac{C_e}{C_e^*} = \frac{K_l^2}{K_r} \frac{1 + \left(\frac{i_{qs}}{i_{ds}}\right)^2}{1 + \left(K \frac{i_{qs}}{i_{ds}}\right)^2} = \frac{1}{K_r} \left(\frac{\varphi_r}{\varphi_r^*} \right)^2 \quad (19)$$

$$K_r = \frac{C_e^*}{C_e} \left(\frac{\varphi_r}{\varphi_r^*} \right)^2$$

Therefore the rotor estimate of resistance is given by following relation:

$$R_r = K_r R_r^* \quad (20)$$

VI. DIGITAL SIMULATION

We studied the case of a control device speed imposing constant flux ψ_{qr} . Flux ψ_{dr} is ordered in open loop to impose the current i_{ds} on a suitable value. The slip as well as the orientation of rotor flux is calculated by using the reference variables ψ_{drref} et i_{qsref} . The two currents i_{ds} et i_{qs} are ordered each one by a regulator proportional integral (PI). The parameters of these regulators are calculated by using software based on the roots places. The decoupling of the currents is calculated from the currents of references. We use the command with constant flux considering its simplicity of implementation (figure.4) with the rotor time constant update.

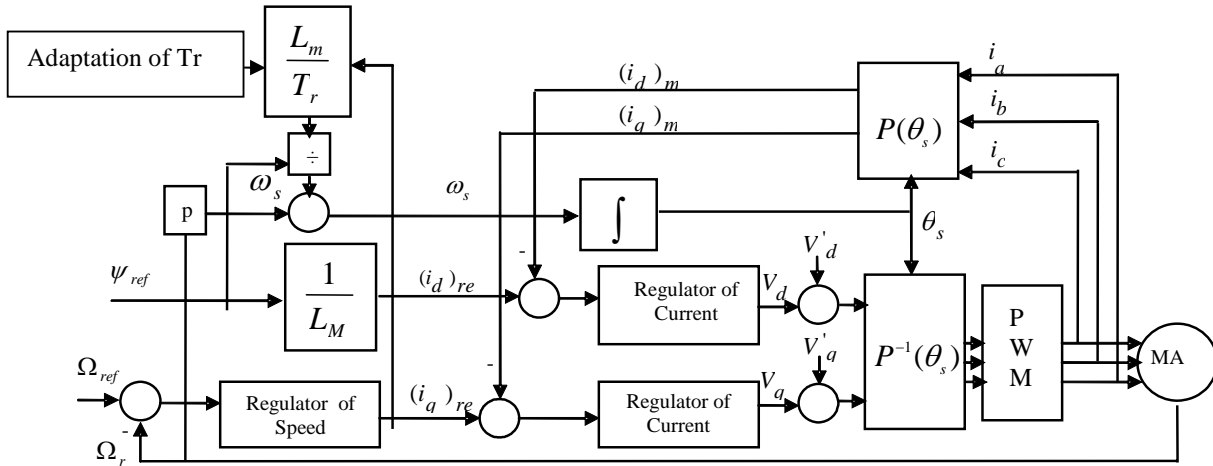

Fig.4 Diagram block of the strategy of command considered

A. Simulation results

The digital simulations that we carried out, relate to the strategy of command described by the diagram block of figure (4) in the two following cases:

a) Figures (5, 6) Response of the system to a level of speed of reference from 0 to 100 (rd) to $t = 0$ sec, and the application of a load equal to the nominal couple to $t = 1$ sec which is regarded as an external disturbance.

b) Figures.7, 8, 9, shows the dynamic responses of the adjustment by orientation of the rotor-flux algorithm of the induction machine supplied by PWM inverter. The stator-currents are controlled by PI regulators. These figures represent the dynamic responses real and reference speed, the torque and rotor flux at a step speed of 100 rd/s followed by an application of a load equal to the nominal torque between 1 sec, then reduced speed to 50 rd/s from 2 sec. Fig.8, the variation of rotor time constant leads to a misalignment of the rotor flux, especially when the machine is loaded and when the reverse, which introduces a coupling between the flux and torque. This coupling can lead to instabilities of the control system. Fig.9), we note that decoupling "Torque-flux" is maintained and show the dynamic responses of rotor flux in particular when applying a load torque and the sudden reversal of speed in the presence of variation of rotor time constant. Thus, the flow direction remains unchanged and for the performance speed. This is achieved through the adaptation of rotor time constant. This shows that the control method provides a vector control robust to perturbations in the presence of variations in rotor time constant.

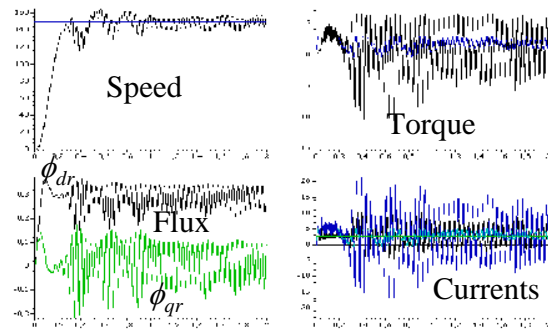

Fig.5 Results of the simulation of the completely discrete command: case where k_d and k_q correspond to the places of the roots being apart from the circle unit

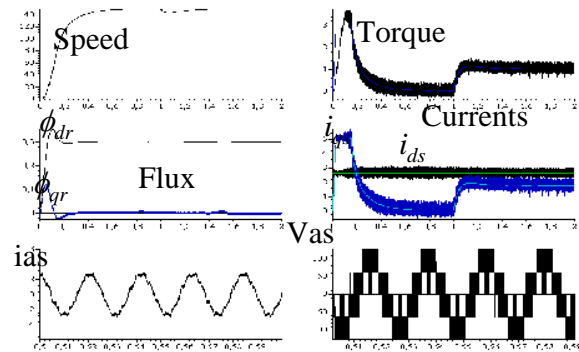

Fig.6 Results of the simulation of the completely discrete command: case where k_d and k_q corresponds to places of roots being at the interior of the circle unit.

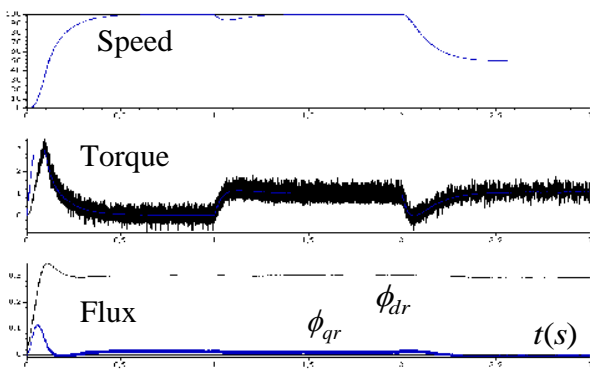

Fig.7 Results of the simulation of the completely discrete command: case where kd, and kq corresponds to places of roots being at the interior of the circle unit, without adaptation of rotor time constant.

Results of the simulation of the completely discrete command: case where kd, and kq corresponds to places of roots being at the interior of the circle unit with a 50% reduction of T_r at $t=1\text{sec}$:

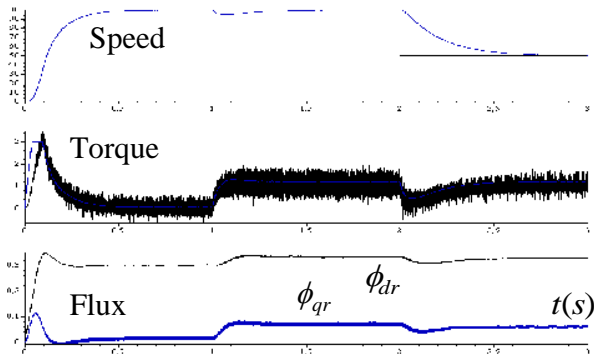

Fig.8 Without adaptation of rotor time constant

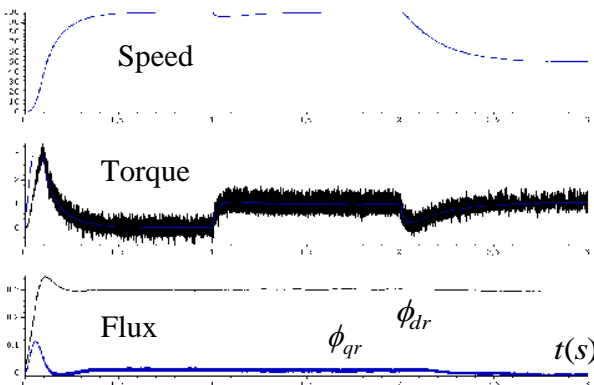

Fig.9 With adaptation of rotor time constant

VII. CONCLUSION

The results of simulation obtained are very satisfaisant. That was possible thanks to the good choice of the values of the parameters of the regulators used which shows, the founded good of the method used, for the choice of the parameters of the discrete regulators and adaptation of rotor time-constant. We also note that the decoupling between torque and flux is

achieved. This demonstrates the robustness of the control algorithm used.

REFERENCES

- [1] E. Gilson, «The brisk A digital signal processor dedicated to the command AC electromechanical actuators», Proc. Of the 19th congress of the international council of the aeronautical sciences, Anaheim California, USA, sep. 1994, vol. 2, pp. 1372-1377.
- [2] J.P. Louis, C .Bergmann «Commande numérique des ensembles convertisseurs machines», RGE n°5/92, Mai 1992. pp.124-133.
- [3] W. Leonhard, «Control of Electrical Drive » .Berlin .Germany: Springer Verlag, 1985.
- [4] A. Larabi, D.Grenier, F. Labrique. « A simplified vector control scheme for an induction motor revisited” 0-7803-4484-7/98/1998 IEEE AMC’98, Coimbra Portugal PP.24.29
- [5] M. Messaoudi, L. Sbita , MN. Abdelkrim «On-line rotor resistance estimation for sensorless indirect vector control of induction motor drives», IEEE Forth Int. Multi-Conf. on Systems, Signals and Devices SSD’07. vol 2, March 19-22, 2007 – El Hammamet, Tunisia.
- [6] M. O. Mahmoudi, « Sur la commande de la machine asynchrone alimentée en tension», Thèse de doctorat d’état, ENP Alger 1999.
- [7] K. Akatsu and A. Kawamura, «Online rotor resistance estimation using the transient state under speed sensorless control of induction motor, » IEEE Trans. Power Electron, vol. 15, no. 3, pp. 553–560, May 2000.
- [8] Y. Miloud, A. Draou, \Fuzzy Logic Based Rotor Resistance Estimator of an Indirect Vector controlled Induction Motor Drive" Conf. Rec. IEEE/ IECON’02 Sevilla, Spain, pp. 961-967, 5-8 November 2002.
- [9] A.Derdiyok, \Simple Metod for Speed and Rotor resistance Estimation of Induction Machines", IEEE Proc-Electr, Power Appl, Vol 150, No.3, May 2003, pp 289-294