

# Particle Swarm Optimization Approach on Flexible Structure at Wiper Blade System

A. Zolfagharian, M.Z. Md. Zain, A. R. AbuBakar, and M. Hussein

**Abstract**—Application of flexible structures has been significantly, increased in industry and aerospace missions due to their contributions and unique advantages over the rigid counterparts. In this paper, vibration analysis of a flexible structure i.e., automobile wiper blade is investigated and controlled. The wiper generates unwanted noise and vibration during the wiping the rain and other particles on windshield which may cause annoying noise in different ranges of frequency. A two dimensional analytical modeled wiper blade whose model accuracy is verified by numerical studies in literature is considered in this study. Particle swarm optimization (PSO) is employed in alliance with input shaping (IS) technique in order to control or to attenuate the amplitude level of unwanted noise/vibration of the wiper blade.

**Keywords**—Input shaping, noise reduction, particle swarm optimization, wiper blade

## I. INTRODUCTION

SINCE the automobiles have come to exist and used as daily transportation means the necessity and significance of a tool like wiper has been perceived in order to sweep the water, snow and mud from the automobile's windshield.

Various sorts of noise in different frequency ranges are generated due to vibration of wiper blade on windscreen. A low frequency sound known as beep noise whose range is nearby 100 Hz is focused in this study to be attenuated. In open literature it is evidenced that the vibration noise called chattering noise is due to deformation of wiper blade during the wiper turnover [1]-[3]. Control of motion and noise reduction of wiper blade can be carried out through manipulating and modifying the wiper physical structure and material used in wiper rubber ([2]-[4]) or suppress the vibration of wiper via various control approaches [5]-[7].

Knowing that a critical issue for designing a controller for a wiping system should be adequately simple to be implemented on microprocessors whose memory are small and compute

slowly, input shaping (IS) as an effective feed-forward controller is chosen for noise reduction of flexible wiper blade [8]. Since Input shaping approach is highly depends on system natural frequencies and damping ratios and meanwhile such accurate information of wiper blade may not be feasible in analytical study; a need to an optimizer is perceived in order to find the accurate time location of impulses. Particle swarm optimization (PSO) is a relatively new method compare to evolutionary algorithms and has been introduced by Kennedy and Eberhart [9] which utilized in several control problems [10], [11]. In this paper a PSO algorithm is employed together with IS controller to adjust the time location of input impulses and it is expected that it can attenuate the amplitude of unwanted noise of wiper blade during its operation.

## II. WIPER BLADE ANALYTICAL MODELLING

In order to eliminate the uncertainties, noise and other unwanted vibration; the knowledge of wiper's dynamic equation is an essential issue. Therefore, the mathematical model of a reversal rubber wiper blade in [12] is fully adopted.

The parameters involved in a spring-mass model of wiper are shown in Fig. 1 and their corresponded values in this case study are listed in TABLE I. Also, detailed geometries of wiper blade structure is given in Fig. 2.

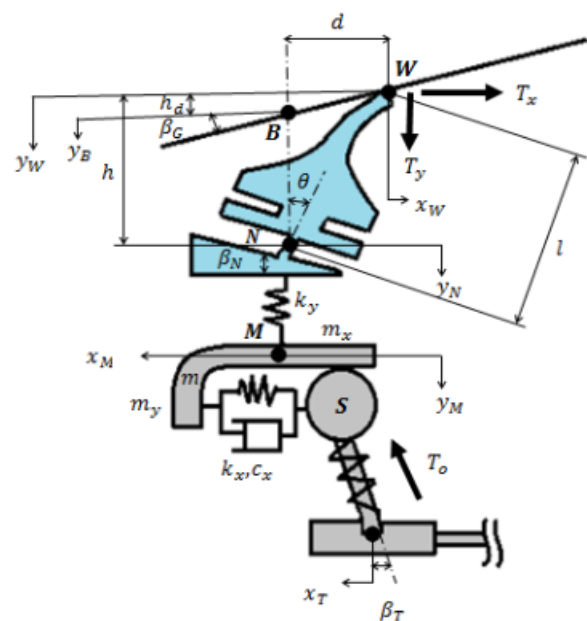

Fig. 1 Spring-mass model wiper blade system [12]

Ali Zolfagharian is with Department of Applied Mechanic, Universiti Teknologi Malaysia, 81310, Skudai, Johor, Malaysia; (e-mail: ali.zolfagharyan@gmail.com).

Mohd, Zarhamdy Md. Zain is with Department of systems and Control, Universiti Teknologi Malaysia, 81310, Skudai, Johor, Malaysia; (e-mail: zarhamdy@fkm.utm.my).

Abd Rahim AbuBakar is with Department of Aeronautics and Automotive, Universiti Teknologi Malaysia; (e-mail: arahim@fkm.utm.my)

Mohamed Hussein is the Head of Control and Automation Panel at the Faculty of Mechanical Engineering, Universiti Teknologi Malaysia; (e-mail: mohamed@fkm.utm.my)

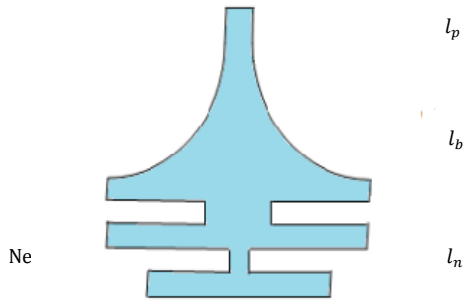

Fig. 2 Cross section view wiper blade [12]

 TABLE I  
 VALUES OF WIPER BLADE EQUIVALENTS PARAMETERS [12]

Parameter	Value	Unit
$m_x$	0.25	kg
$m_y$	0.21	kg
$k_a$	0.023	N.m/rad
$k_c$	9	kN/m
$k_x$	5	kN/m
$k_y$	30	kN/m
$c_x$	5	N.s/m
$c_y$	10.072	N.s/m
$\theta$	0.262	rad
$l$	0.004	m
$T_{y0}$	9.2	N

The equivalent masses  $m_x$  and  $m_y$  have been defined in terms of the rotation of blade in x and y direction around the arm pivot and arm hinge respectively.

with assuming the center of rotation at point  $M_r$  the length of the rubber is:

$$l = l_n/2 + l_b + l_p \quad (1)$$

Due to rubber deformation the reaction force,  $P$  is generated as follow:

$$P = k_a \beta_a / l = k_c \quad (2)$$

Where  $\beta_a = \theta - \beta_N$ , is angle of rubber neck and  $\beta_N$  is twist angle of arm front.

The initial reaction forces stand in x and y direction can be obtained based on Newton second law on windscreen as [12]:

$$T_{x0} = (-\sin\beta_N / \cos(\beta_T + \beta_N)) T_0 \quad (3)$$

$$T_{y0} = (\cos\beta_N / \cos(\beta_T + \beta_N)) T_0$$

While  $\beta_T$  is twist angle of blade tail.

In the present model of wiper blade five various circumstances may be occurred so those lead to five different groups of equation of motion [12]. In this study, it is assumed

that rubber head and rubber shoulder are not touching each other and the blade lip and wind shield are in a slip condition. Based on Fig. 1 and Eqs(2), (3), the sum of forces in the x and y-directions can be stated as [12]:

$$m_x(\ddot{x}_W + \ddot{d}) + c_x((\dot{x}_W + \dot{d}) + \dot{y}_M \tan\beta_T - \dot{x}_T) + k_x((x_W + d) + y_M \tan\beta_T - x_T) + T_{x0} = (-\sin\beta_N / \cos(\beta_T + \beta_N)) T_0 = 0 \quad (4)$$

$$m_y \ddot{y}_M + c_y[\dot{y}_M - \{(\beta_G - l\theta_G \sin\theta)\dot{x}_M - l\beta_G \dot{\beta}_a \cos\theta\}] + c_x\{l\dot{\beta}_a\{(1 + 1/K)\cos\theta - (\beta_a/K)\sin\theta\} + (\dot{y}_M \tan\theta_H - \dot{x}_T) + k_x\{(x_W + l\{\sin\theta + (\beta_a/K)\cos\theta\} + y_M \tan\beta_T - x_T)\}\tan\beta_T\} - [k_y(y_M - y_N) + (\cos\beta_N / \cos(\beta_T - \beta_N))T_0] + (\cos\beta_N / \cos(\beta_T - \beta_N))T_0 = 0 \quad (5)$$

### III. INPUT SHAPING

Input shaping's mathematic derivation for two-impulse sequence can be obtained by a second order system as following.

The residual vibration resulted from a series of impulses utilized in the system can be derived as [8]:

$$V(\omega, \xi) = \exp^{-\xi\omega n} \sqrt{\left(\sum_{i=1}^n P_i(\omega, \xi)\right)^2 + \left(\sum_{i=1}^n Q_i(\omega, \xi)\right)^2}$$

$$P_i = A_i \exp^{-\xi\omega t_i} \cos\varphi_i$$

$$Q_i = A_i \exp^{-\xi\omega t_i} \sin\varphi_i \quad (6)$$

$$\varphi_i = \omega_d t_i$$

$$\omega_d = 2\pi f_n \sqrt{1 - \xi^2}$$

Where  $A_i$  is amplitude,  $t_i$  represents the time of the impulses and  $n$  is the number of impulses in the impulse sequence and  $f_n$  and  $\xi$  are  $n$ th natural frequency and damping ratio of system respectively.

In order to achieve the zero residual vibration; the amplitude of a sequence of two impulses and their time location should be determined by solving (6) alongside some premises which should be taken into account to obtain non-trivial solutions as [13], [14]:

$$A_1 = 1/1 + G, t_1 = 0 \quad (7)$$

$$A_2 = G/1 + G, t_2 = Td/2$$

Where  $G = \exp^{-\xi\pi/\sqrt{1-\xi^2}}$  and  $Td = 2\pi/\omega_d$  is damped period of system.

### IV. PARTICLE SWARM OPTIMIZATION

PSO has a population base algorithm in which some initial solutions are chosen which called particles. Each particle is

represented with its position and velocity. In first step, the algorithm is initialized with a number of random particles. The term dimension is defined as the number of decision maker in the problem; it means a problem with two variables corresponds to a two dimensions problem in particle swarm. Arbitrary appointed particles surf through the dimension(s) space of problem to look for the new solutions. Like other optimization methods a fitness function is defined that can calculate the certain objective of problem.

After initializing the nominee particles, PSO's construction factor algorithm updates all the initial velocities and positions at each epoch as follow [15]:

$$V_i^{t+1} = K[V_i^t + C_1 U_1(p_i - X_i^t) + C_2 U_2(p_g - X_i^t)] \quad (8)$$

Where K is named the constriction factor and defined as follow:

$$K = 2/[2 - \varphi - \sqrt{\varphi^2 - 4\varphi}] \quad (9)$$

$$\varphi = C_1 + C_2 > 4.$$

K should be assigned a value between zero and one in order to convergence of algorithm. As it has been formulated K is ultimately a function of  $C_1$  and  $C_2$  that named self-recognition component and coefficient of the social component respectively and both are positive constants.  $X_i$  and  $V_i$  are the vectors of position and velocity of  $i$ th particle respectively.  $p_i$  is the best position of previous fitness value of  $i$ th particle.  $p_g$  represents the fittest particle among the all fitness values in the swarm.  $U_1$  and  $U_2$  are random numbers in the range of [0, 1].

For more comprehending the process of algorithm it can be supposed that the new velocity of each particle are comprised of three components which navigate the particle toward its best position, the global best position in previous level and same direction of last particle velocity. The best personal (pbest) and global (gbest) particles are acted like two attraction points which draw the particle somewhat toward themselves (Fig. 3).

Finally, new position of each particle is calculated as:

$$X_i^{t+1} = X_i^t + V_i^{t+1} \quad (10)$$

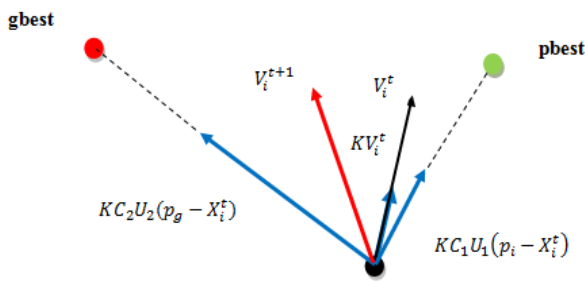

Fig. 3 Particles mechanism to get new position

In this study PSO is assigned as a fast and relatively accurate optimization algorithm to find the best time location of input impulses so that reduce unwanted noise of wiper blade (Fig. 4).

### V. RESULTS AND DISCUSSIONS

In this section simulation of wiper blade are presented in the x and y directions. These simulation results are verified by numerical and experimental results that already existed in the open literature [16].

A double switch bang-bang velocity (Fig. 5) is considered as input of amplitude 0.2 m/s in system at time interval of 10 seconds.

The behavior of wiper blade in the x and y- direction with the unshaped bang-bang velocity input in time domain and frequency domain are illustrated in Fig. 6 and Fig. 7 in which the maximum amount of end point acceleration in x and y-direction are  $4.8 \text{ m/s}^2$  and  $1.9 \text{ m/s}^2$  and the highest power spectrum density (PSD) of end point acceleration in frequency domain are  $23.1 \times 10^{-3} (\text{m/s}^2 * \text{m/s}^2)/\text{Hz}$  at 97.5 Hz and  $3.34 \times 10^{-3} (\text{m/s}^2 * \text{m/s}^2)/\text{Hz}$  at 126.35 Hz respectively.

The earlier result has proved a closed correlation between the analytical results and numerical results in which the maximum amplitude of wiper vibration in the x and y-direction occurred at 99.08 Hz and 137.46 Hz respectively.

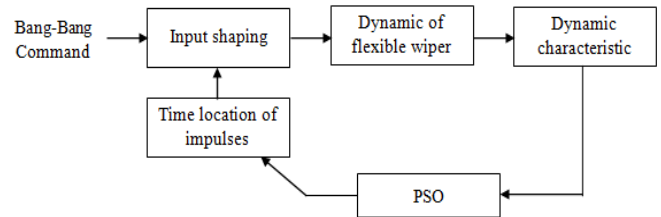

Fig. 4 Block diagram of collaboration of PSO and IS

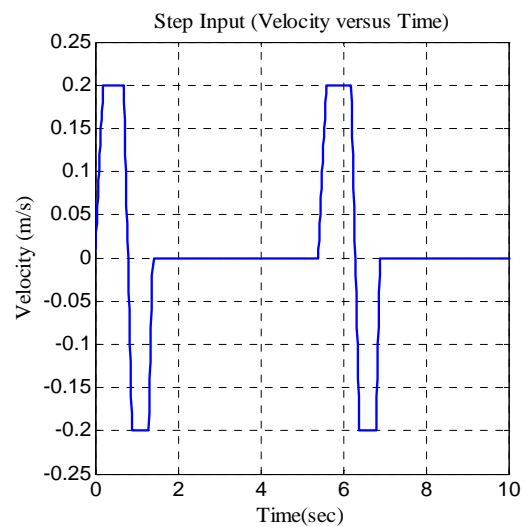

Fig. 5 The bang-bang input velocity

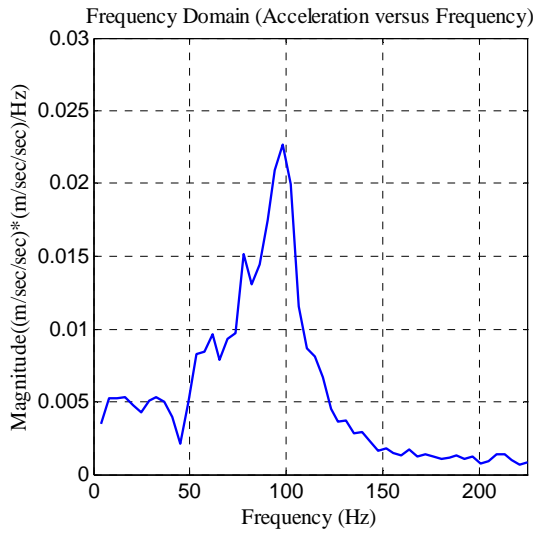

Fig. 6 PSD of end point acceleration free controller in x- direction

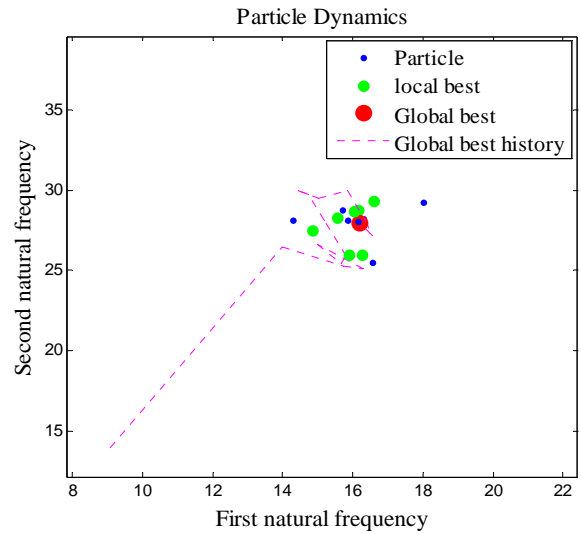

Fig. 8 Particles movement

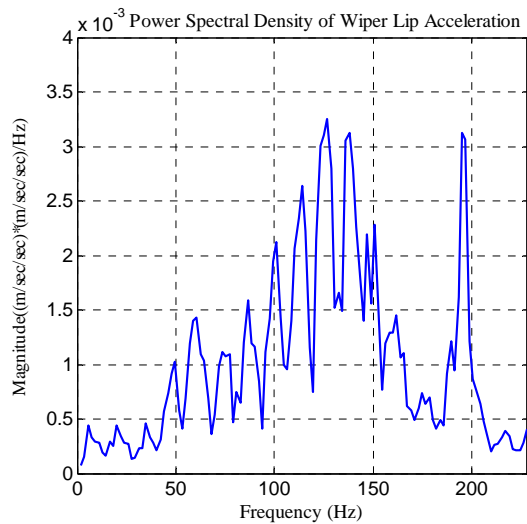

Fig. 7 PSD of end point acceleration free controller in y- direction

It is shown that the first and second natural frequencies of system are obtained at 15.079 Hz and 28.3729 Hz respectively after 6 epochs of PSO algorithm. So, the optimized time location and amplitude of shaper impulses have been obtained and after convolving with bang-bang input has been sent into wiper system (Fig. 10).

Stick-slip condition is a phenomenon caused via interactions between rubber blade and windshield in the x-direction. The oscillation of wiper blade during the stick-slip situation causes more unwanted noise. From Fig. 11 it can be seen that the stick-slip behavior of current wiper blade has reduced significantly by applying the PSO in collaboration with IS compare to free of controller input. Jump condition is a phenomenon that happens when rubber blade leave the windshield surface during the movement in y- direction. This effect leads to adverse consequences like annoying noise and discomfort vision for driver and occupants. From Fig. 12 the jump duration of the wiper blade has been shortened to 0.075 seconds.

A PSO algorithm is applied on the path of bang-bang input in this stage to find the most appropriate time location of input shaper impulses as well as their amplitude which strongly dependent on the natural frequencies and the damping ratios of the system. The area under graph of wiper lip acceleration in terms of time is determined as an objective function to be minimized by means of PSO.

Acceleration constants of PSO algorithm is taken as equaled to 2.08 for both  $C_1$  and  $C_2$  and the construction factor is calculated as constant value of -0.67 subsequently. In Fig. 8 and Fig. 9 the convergence of PSO algorithm with 8 particles and particles' dynamic to find the closest values of frequencies and damping ratios to actual ones are illustrated.

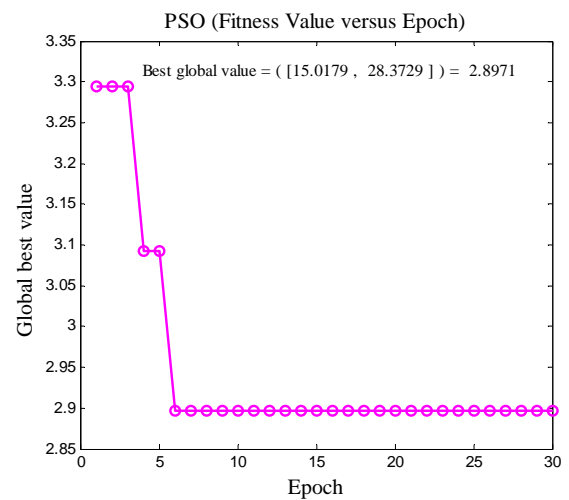

Fig. 9 Convergence of PSO to get the global best value

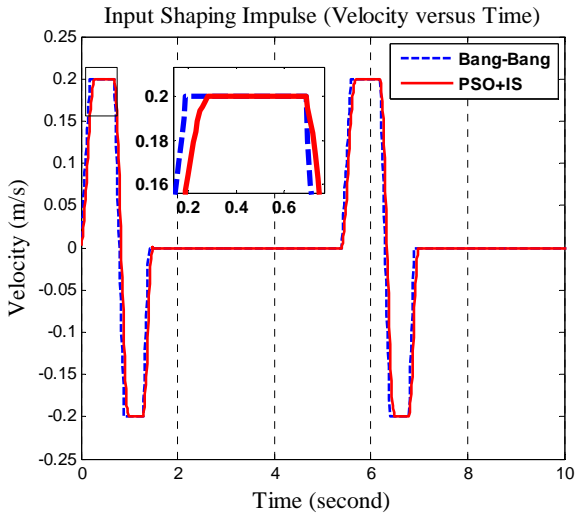

Fig. 10 Convoluted input resulted from PSO+IS

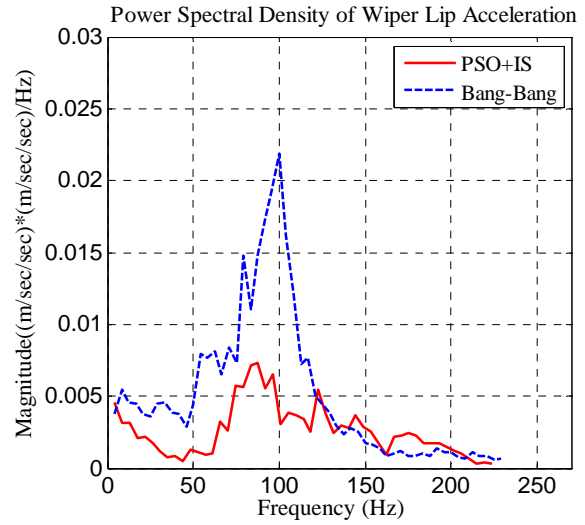

Fig. 13 PSD of end point acceleration response in x- direction

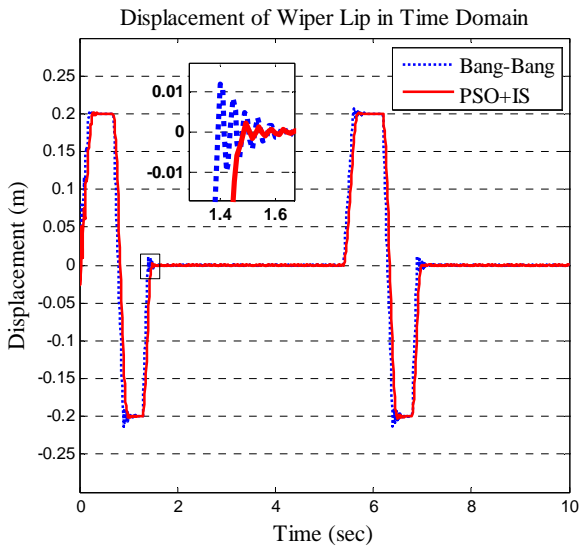

Fig. 11 slip-stick situation in x- direction

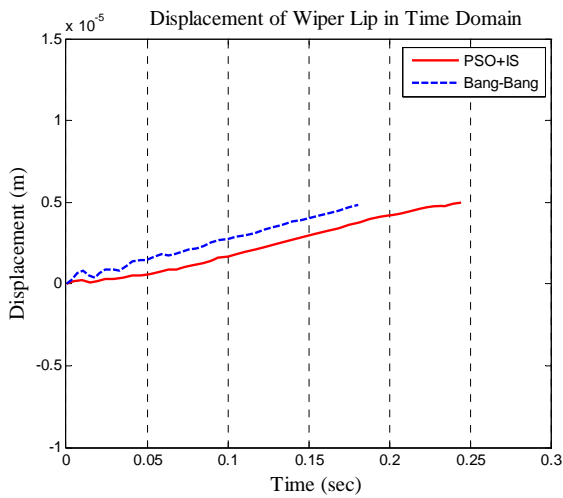

Fig. 12 Jump condition in y- direction

Fig. 13 presents the maximum magnitude of noise in x-direction that has been decreased from  $23.1 \times 10^{-3} (m/s^2 * m/s^2)/Hz$  to  $7.1 \times 10^{-3} (m/s^2 * m/s^2)/Hz$  by utilizing the PSO in cooperation with input shaping controller. Also, acceleration reduction of wiper lip in the x- direction is observed in Fig. 14.

Likewise x- direction the effects of using PSO to find the best time location of input shaping impulses compare to bang-bang input in y- direction are shown in Fig. 15 and Fig. 16 in frequency domain and time domain respectively. Fig. 15 obviously illustrates that the power spectral density (PSD) of wiper blade in the y- direction after using PSO has been reduced from  $3.34 \times 10^{-3} (m/s^2 * m/s^2)/Hz$  to  $2.71 \times 10^{-3} (m/s^2 * m/s^2)/Hz$ .

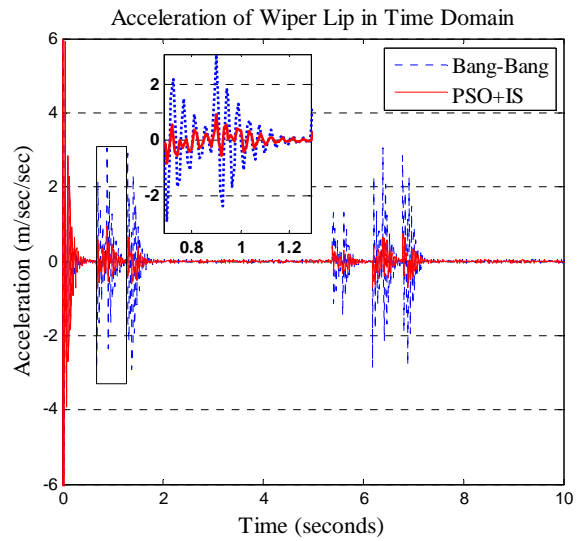

Fig. 14 end point acceleration in x- direction

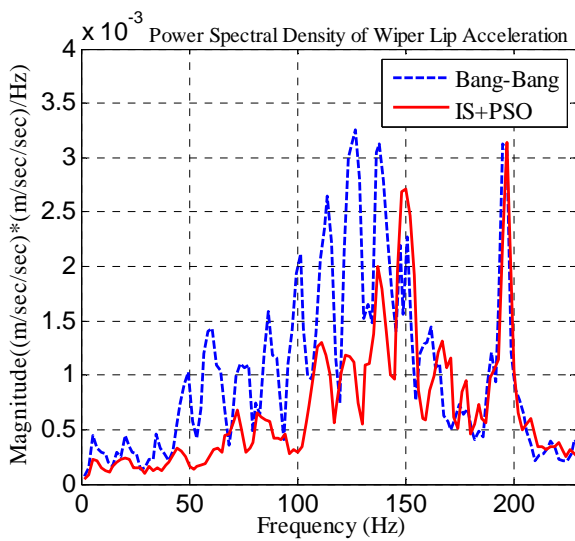

Fig. 15 PSD of end point acceleration response in y- direction

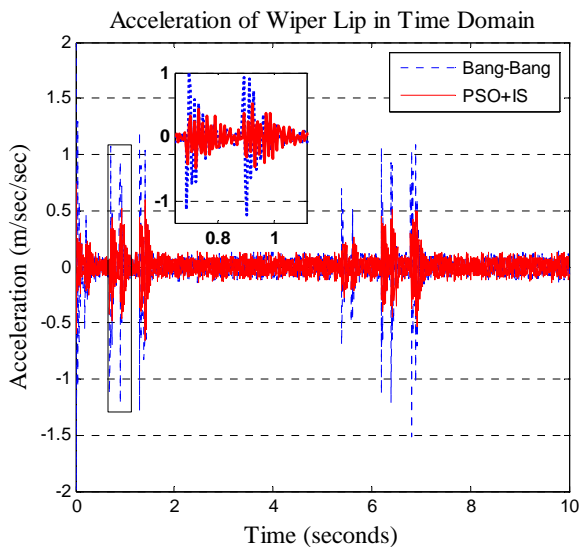

Fig. 16 end point acceleration in y- direction

## VI. CONCLUSION

In this study particle swarm optimization method as a fast and accurate population base optimization method is fully utilized to determine the most suitable time location of input shaping impulses so that unwanted noise of automobile wiper blade known as beep noise in both x and y- directions can be reduced significantly. Furthermore, the stick-slip and jump condition which represent the oscillation behavior of wiper blade in time domain for the x and y- direction have been improved using the PSO in associating with IS controller.

## REFERENCES

- [1] S. Goto, H. Takahashi, T. Oya, "Investigation of wiper blade squeal noise reduction measures," SAE technical paper, vol. 1, pp. 1410, April 2001.

- [2] R. Grenoullat, C. Leblanc, "Simulation of chatter vibrations for wiper system" SAE Technical Paper, vol. 1, pp. 1239, 2002.
- [3] A.R. Abu Bakar, M.Z. Md Zain, "Modeling and simulation wiper noise and vibration using finite element method", 2nd Regional on Vehicle Engineering and Technology, 2008.
- [4] I.M. Awang, A.R. Abu Bakar, B.A. Ghani, R.A. Rahman, and M.Z.M. Zain, "Complex eigenvalue Analysis of Windscreen Wiper Chatter Noise and its Suppression by Structural Modifications," Int. J. Vehicle Structures & Systems, vol. 1 no. 1-3, pp. 24-29, 2009
- [5] KA. C. Cheok, K. Kobayashi, S. Scaccia, G. Scaccia, "fuzzy logic-based smart automatic windshield wiper," Control Systems Magazine, IEEE, vol. 16 no.:6, pp. 28-34 Dec1996.
- [6] J.H. Park, M.H. Kim, H.J. Im, K.C. Lee, S. Lee, "Development of Vision based Control Smart Windshield Wiper System for Intelligent Vehicle," Int. Joint Conf. SICE-ICASE, 18-21 Oct. 2006, Busan, pp. 4398 – 4403.
- [7] J. Lévine, "On the Synchronization of a Pair of Independent Windshield Wipers," IEEE Trans. on Control Systems Technology, vol. 12 no. 5, pp. 55-57, 2004.
- [8] N. C. Singer and W. P. Seering, "Reshaping command inputs to reduce system vibration," Trans. of ASME: J. of Dynamic Systems, Measurement and Control, vol. 112 no. 1, pp. 76–82, 1990.
- [9] J. Kennedy and R. C. Eberhart, "Particle swarm optimization," Proceedings of the IEEE Int. Conf. on Neural Networks (ICNN), 1995, Perth, Australia, pp. 1942–1948.
- [10] K. Teeyapan, W. K. Jiuguang, M. Stilman, "Robot limbo: Optimized planning and control for dynamically stable robust under vertical obstacles," Robotics and Automation (ICRA), IEEE Int. Conf. Anchorage, AK. pp. 4519 – 4524, 3-7 May 2010.
- [11] S. Tavakoli and A. Banookh, " Robust PI Control Design Using Particle Swarm Optimization," J. of Computer Science and Engineering, vol. 1 no. 1, pp. 36-41, 2010.
- [12] S. Okura and T. Sekiguchi, " Dynamic Analysis of Blade Reversal Behaviour in a Windshield Wiper System," SAE 2000 World Congress. 6-9 March.
- [13] A.K.M. Azad, M.H. Shaheed, Z. Mohamed, M.O. Tokhi and H. Poerwanto, "Open-loop control of flexible manipulators using command-generation techniques," In M.O. Tokhi and A.K.M. Azad (Ed.) "Flexible robot manipulators modelling, simulation and control," London, United Kingdom: The Institution of Engineering and Technology, 2008, pp. 207-233.
- [14] A. Zolfagharian, Optimization Techniques for Vibration Control of Wiper Blade System. Ms. E., UTM, Skudai, Johor, Malaysia, pp 45-48, April 2011.
- [15] M. Clerc, "The swarm and the queen: towards a deterministic and adaptive particle swarm optimization," Proc. Congress on Evolutionary Computation, IEEE Service Center, Detroit, Michigan Washington, DC. Piscataway, pp. 1951-1957, 1999.
- [16] M. A. Salim, A. Noordin, M. Z. Md. Zain and A. R. Abu Bakar, "The Analysis of fiction Effect in Automative Wiper system Using input Shaping scheme Technique," The 2010 Int. Conf. of Mechanical Engineering (WCE). 30 June – 2 July 2010, pp. 1951-1957, London, England.