

# An Experimental Study on Evacuated Tube Solar Collector for Heating of Air in India

Avadhesh Yadav, V.K. Bajpai

**Abstract**—A solar powered air heating system using one ended evacuated tubes is experimentally investigated. A solar air heater containing forty evacuated tubes is used for heating purpose. The collector surface area is about 4.44 m<sup>2</sup>. The length and outer diameters of the outer glass tube and absorber tube are 1500, 47 and 37 mm, respectively. In this experimental setup, we have a header (heat exchanger) of square shape (190 mm x 190 mm). The length of header is 1500 mm. The header consists of a hollow pipe in the center whose diameter is 60 mm through which the air is made to flow. The experimental setup contains approximately 108 liters of water. Water is working as heat collecting medium which collects the solar heat falling on the tubes. This heat is delivered to the air flowing through the header pipe. This heat flow is due to natural convection and conduction. The outlet air temperature depends upon several factors along with air flow rate and solar radiation intensity. The study has been done for both up-flow and down-flow of air in header in similar weather conditions, at different flow rates. In the present investigations the study has been made to find the effect of intensity of solar radiations and flow rate of air on the out let temperature of the air with time and which flow is more efficient. The obtained results show that the system is highly effective for the heating in this region. Moreover, it has been observed that system is highly efficient for the particular flow rate of air. It was also observed that down-flow configuration is more effective than up-flow condition at all flow rates due to lesser losses in down-flow. The results show that temperature differences of upper head and lower head, both of water and surface of pipes on the respective ends is lower in down-flow.

**Keywords**—air flow direction; Evacuated tube solar collector; solar air heating; solar thermal utilization

## I. INTRODUCTION

WE are going through the period of energy crisis. it is due to the prolonged use of electricity which is produced by fuels like coal, gas, diesel etc. these fuels' byproducts affect our environment very badly resulting in global warming, ozone layer depletion, acid rain. It is not good for human life. Now we are at the stage where the search for other alternative methods that replace the electricity has become pinnacle. This work is essentially based on the alternative methods by which we can reduce the consumption of electricity. Solar air heating is pollution free and the running cost is very low. It is environment friendly. It opens the choice of ventilation. However, its initial cost is high and works only in daytime. It does not work properly in cloudy as well as foggy conditions.

In this experimental setup, we are using small amount of electricity for forced convection which we can easily replace. Evacuated tube solar collector has been commercially available for over 25 years. However until recently they have not provided any real competition to flat plate collector. In winter season, due to very low temperature we have to use an electric heater and small furnace by which we can get hot air which runs through the coal and agricultural waste which affects the climate and agriculture. But it causes breathing problems to occur because there isn't any ventilation mode and it consumes so much of electricity. In this project our main aim is to reduce the electricity consumption along with making it human friendly. This paper analyzes and discusses the performance results of solar air heater based on evacuated tube solar collector. The design was fabricated by manufacturer and installed at NIT Kurukshetra, India for testing and field performance. This paper presents the thermal performance of solar air heating with evacuated tubes. A review of literature suggests that considerable effects have been invested in research and development of solar air heater technology. Developed a radiation model for evacuated collector with tubular absorber [1]. Investigated the tube geometry and panel design of evacuated tube solar collector [2]. Developed a geometrical method to determine the size and position of shadow on area of each tube [3]. measured the typical performance of the water in glass evacuated tube solar water heater [4]. The performance of water in glass evacuated tube solar pre heater is investigated [5]. A prototype collector with parallel-connected evacuated double glass tubes are investigated theoretically and experimentally and They also work at the distance between the tubes, solar azimuth angle, and expected yearly thermal performance for different climates [6]. He evaluates the characteristics of water in glass evacuated tube solar water heater including assessment of circulation rate through single ended tubes [7]. He developed a numerical model of heat transfer and fluid flow inside a single ended tube. Developed the experimental and numerical correlation for natural circulation flow rate through single ended water in glass evacuated tubes mounted over a diffused reflector [8]. He investigated heat transfer and flow structures inside the glass evacuated tubes for different flow operating conditions by computational fluid dynamics [9]. He investigated the thermal performance of glass evacuated solar collector numerically and experimentally [10]. He investigated and estimated the CO<sub>2</sub> based solar collector. On the basic characteristics such as CO<sub>2</sub> temperature and pressure in collectors, CO<sub>2</sub> flow rate and collector performance [11]. Investigated the performance of water in glass evacuated tube solar water heater using experimental setup of optical and heat loss characteristics and a simulation model of thermosyphon circulation in single ended tube [12]. Investigated the thermal performance of the individual glass evacuated tube solar collector by analytical method [13].

Avadhesh Yadav, Department of Mechanical Engineering National Institute of Technology, Kurukshetra Haryana-136119, India(phone:+91-01744-233470;fax+91-01744-238.50;e-mail:avadheshyadava@gmail.com)  
V.K. Bajpai Department of Mechanical Engineering National Institute of Technology, Kurukshetra Haryana-136119, India(phone:+91-01744-233460;fax+91-01744-238.50;e-mail:@gmail.com)

**Nomenclature**

- $A_C$  the outer surface area of absorber tube,  $m^2$
- $A_p$  the diffuse reflection area of solar collector,  $m^2$
- $C_p$  specific heat of air,  $J/Kg K$
- $D$  outer diameter of absorber tube,  $m$
- $h_r$  radiation heat transfer coefficient,  $(W/m^2 K)$
- $I_0$  Solar Intensity,  $W/m^2$
- $L$  the length of absorber tube,  $m$
- $m$  mass flow rate of working fluid,  $(Kg/s, m^3/hr)$
- $Q_L$  thermal loss,  $W$
- $Q_u$  net heat energy absorbed by working fluid,  $W$
- $T_a$  ambient temperature,  $K$
- $T_g$  the temperature of outer glass tube,  $K$
- $T_p$  the temperature of the absorber tube,  $K$
- $U_e$  the edge loss coefficient of the header tube,  $W/(m^2 K)$
- $U_L$  overall loss coefficient,  $W/(m^2 K)$

**Greek**

- $\epsilon$  the emissivity of the selective absorbing coating
- $\eta$  Solar collector efficiency
- $\sigma$  Stefan-Boltzman constant

**II. EXPERIMENTAL SETUP**

The aim of the experimental work is to study the performance of a solar air heating with one end closed evacuated tubes in India. For this reason, an experimental system has been designed and built. The test section of solar air heater is based on glass evacuated tube. In this system as shown in figure, it consists of forty evacuated tubes and a header (heat exchanger). The length and outer diameters of the outer glass tube and absorber tube are 1500, 47 and 37 mm, respectively. The collector is inclined at an angle of  $15^\circ$  relative to horizontal. A blower with power of 0.335 KW is used to blow the air in the solar air heater. The air flow rate is controlled using a controlling unit.

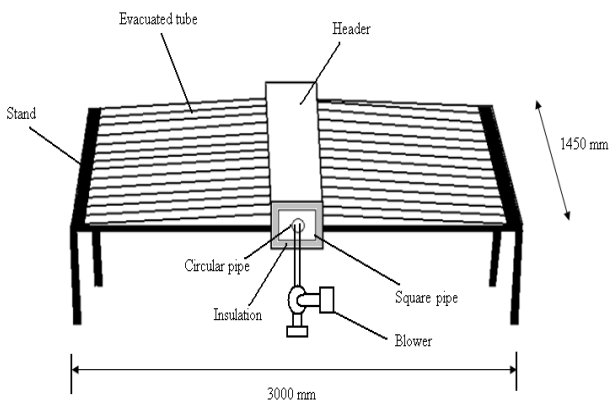

Fig.1 Schematic of solar air heating based on evacuated tube solar collector



Fig. 2 Experimental apparatus with up-flow

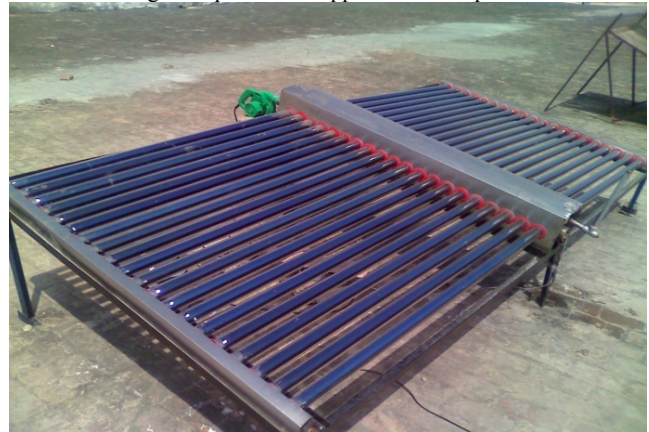

Fig.3 Experimental apparatus with down flow

The main parts of the test setup are shown in the schematic diagram in Fig. 1. A photograph of the system used is shown in fig.4 & fig. 5. The system consists of following parts:

*A Evacuated Tubes:*

The test section of the evacuated tube used in this system is shown in figure. Each evacuated tube consists of two glass tubes made from extremely strong borosilicate glass. It consists of two glass tubes between which a vacuum is present. The outer tube is transparent allowing light rays to pass through with minimal reflection. The inner tube is coated with a special selective coating (Al-N/Al) which features excellent solar radiation absorption and minimal reflection properties. The length of evacuated tube is 1500 mm and the outer and inner diameter is 47 and 36mm.

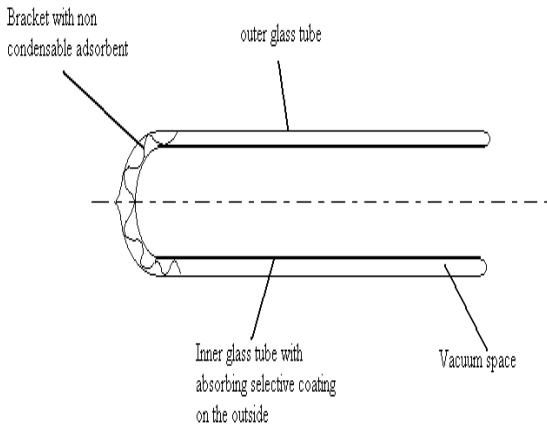

Fig.4 Illustration of glass evacuated tube

**B Header (Heat Exchanger)**

The test section of the Header (heat exchanger) used in this system is shown in figure. The outer body of the header is made up of the cast iron. It consists of a square pipe which is of steel. In this pipe, we have forty holes, 20 on each side in which the evacuated tubes are placed. Open end of the evacuated tubes are in these holes and the closed end are supported by the frame. Outer the square pipe, we have an insulation of glass wool material to stop the heat transfer from the header to atmosphere. The header consists of a hollow pipe in the centre whose diameter is 60 mm through which the air is flowing. This header also contains a safety valve by which the extra amount of heat is extracted to the atmosphere.

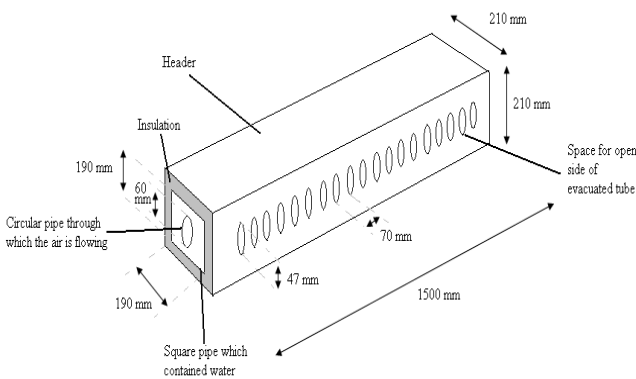

Fig.5 Schematic diagram of a header (Heat exchanger)

**III. MEASURING DEVICES INSTRUMENTS**

Different parameters are measured in this work; these include:

- Inlet and Outlet Air Temperature
- Low and high head Surface Temperature
- Low and high head water Temperature
- Solar radiation intensity
- Air flow rate

RTD PT100 thermocouples are used to measure the temperatures at different points. The thermocouples are connected with a digital temperature indicator that gives the temperature with a resolution of 0.1°C. The solar radiation intensity is measured during the day using a Pyranometer which is supplied by CM11 Kipp and Zonen, Holland. The air flow rate was measured at the beginning of experimental work. An anemometer is used to measure the velocity of air with an accuracy of 0.1 m/s. The experimental data are recorded at intervals of 1h during the daytime. The experiments were carried out during some selected clear sky days from 1 January 2011 to 28 June 2011.

**IV. SYSTEM OPERATION**

The experimental setup contains 108 liter water .Water is working as heat collecting medium which collects the solar heat falling on the tubes. This heat is delivered to the air flowing through the header pipe. This heat flow is due to natural convection and conduction.This setup contains a header and evacuated tubes which is full of water. According to intensity, this water carries heat through the tubes and come in a header due to thermosyphon circulation. This heat is delivered to header. The header contains a pipe in which heat exchange to the air which is passing through this pipe.

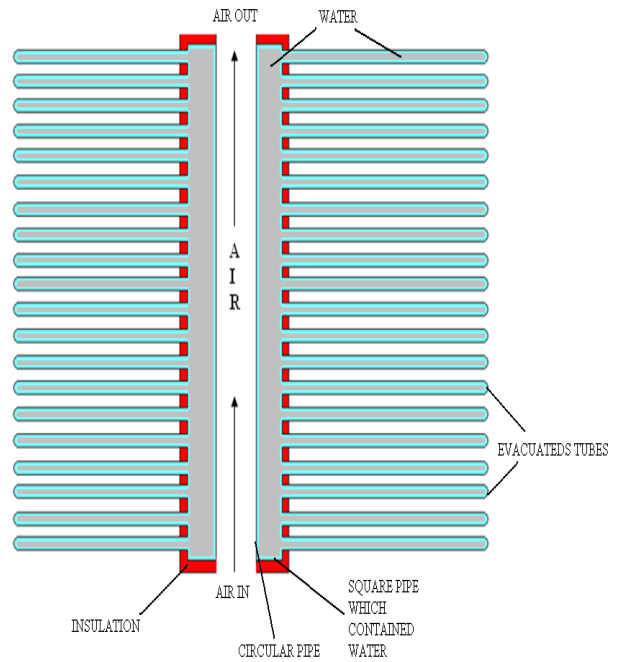

Fig. 6 Top view of an all glass evacuated tube collector

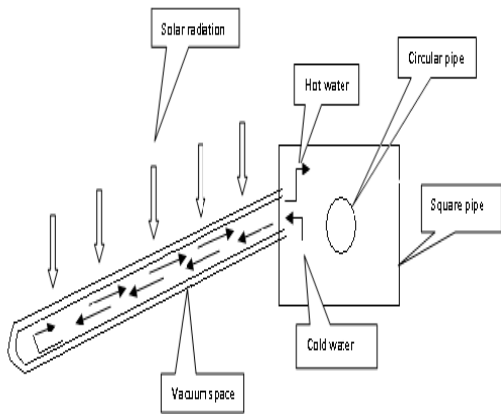

Fig. 7 Heat transfer and Natural circulation flow of water in evacuated tube

This header consists of two heads i.e. high head and low head. Due to thermosyphon, the temperature of water which is present at high head has high temperature than low head. The water which is in header gives heat to the circular pipe. The air temperature will increase when it comes in contact with the circular pipe and it works just like heat exchanger.

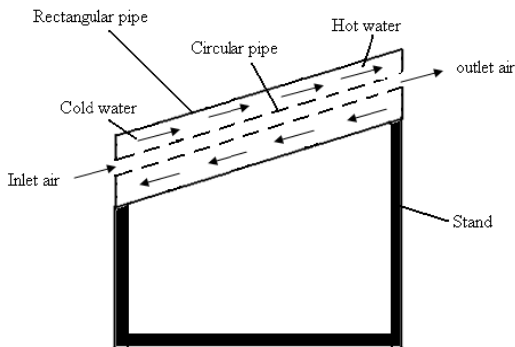

Fig.8 Schematic of a header with up-flow of air

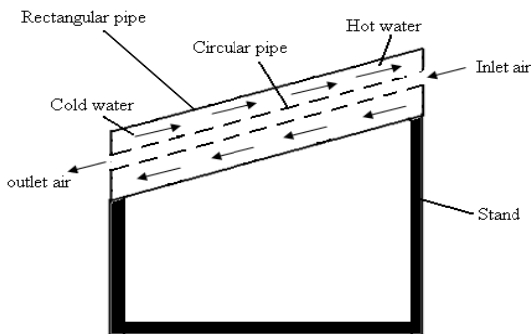

Fig.9 Schematic of a header with down-flow of air

V.COLLECTOR PERFORMANCE THEORY

Evacuated tube consists of two glass tubes, outer tube and absorber tube which is fused together at one end. Other end is open. Absorber tube has an absorbing coating on outer surface. We create vacuum in between the two tubes by sucking air. So the solar energy can be absorbed well because thermal losses are very small due to no conductive and convective heat loss. The thermal performance of the glass evacuated tube solar collector can be estimated by the solar collector efficiency factor,  $\eta$ , which is defined as the ratio between the net heat gain and the solar radiation energy based on diffuse reflection area of solar collector  $A_p$ . [13]

(1)

VI.EXPERIMENTAL RESULTS

A. For upward direction

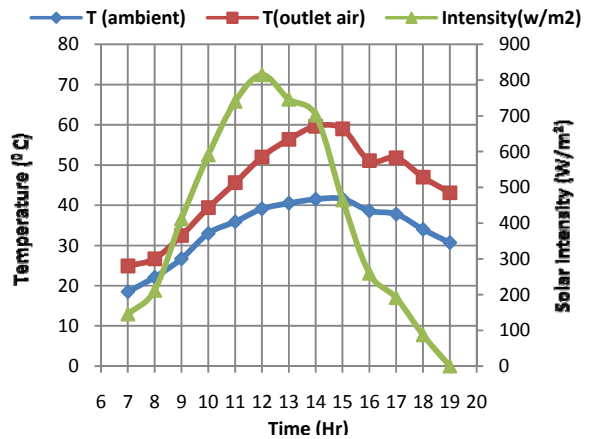

Fig.10 Variation of air collector inlet air, out let air and radiation intensity during day 162.86 m<sup>3</sup>/hr air flow rate

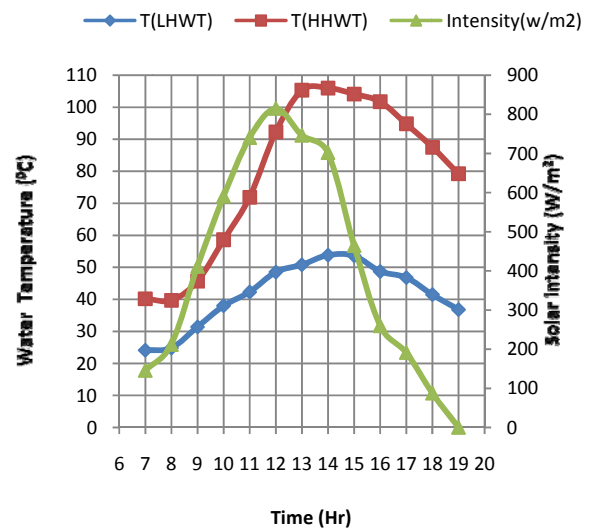

Fig.11 Variation of air collector low head water temperature, high head water temperature in header and radiation intensity during day

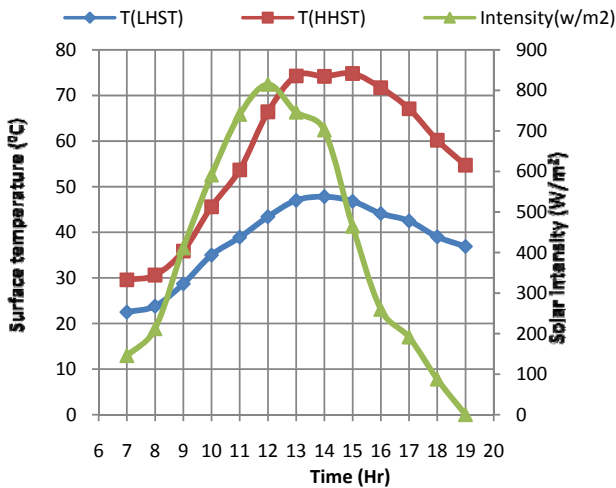

Fig.12 Variation of air collector low head surface temperature circular pipe, high head surface temperature in circular pipe and radiation intensity during day

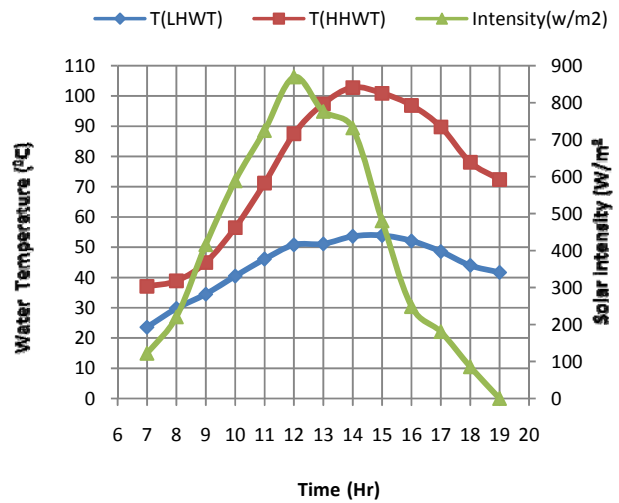

Fig.14 Variation of air collector low head water temperature, high head water temperature in header and radiation intensity during day

*B For downward flow*

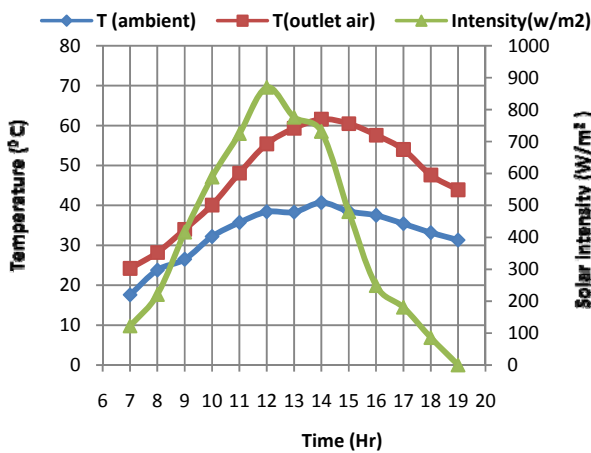

Fig.13 Variation of air collector inlet air, out let air and radiation intensity during day 162.86 m³/hr air flow rate

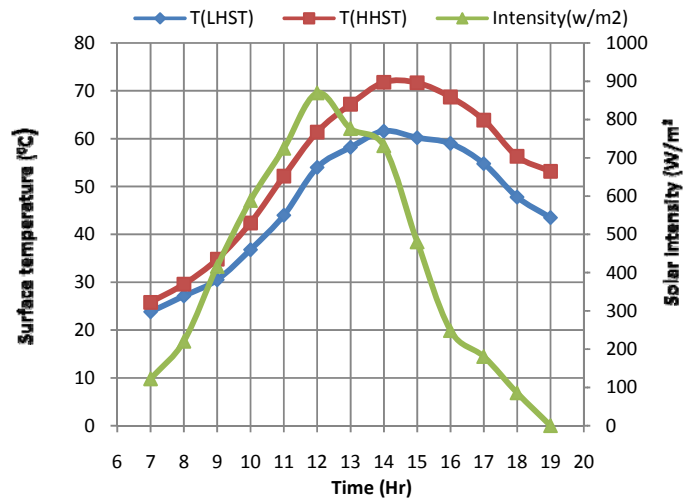

Fig.15 Variation of air collector low head surface temperature circular pipe, high head surface temperature in circular pipe and radiation intensity during day

VII.CONCLUSIONS

At the same operating conditions in downward flow and upward flow, a temperature of 60°C or more is achievable in downward flow. Such an outlet temperature in upward flow is not achieved because of losses in upward flow. The results show that temperature differences of upper head and lower head, both of water and surface of pipes on the respective ends is lower in down-flow. Thus the efficiency of downward flow is much better.

REFERENCES

- [1] R Perez et al. (1995), 'Calculating solar radiation received by tubular solar-energy collectors', Solar Engineering; I: 699-704.
- [2] L Qin (1999), 'Evaluation of evacuated tubular solar-collectors for large SDHW systems and combined space-heating systems', Proceedings of northsun99, Edmonton, Alberta, Canada.
- [3] S Lart (2000), 'Development of a thermal performance test for an Integrated collector-storage solar water heating system', PhD Thesis, pp

- 90-100, Division of mechanical engineering and energy studies, university of Wales Cardiff.
- [4] G.L. Morrison et al. (2001), 'Water in glass evacuated tube solar water heaters', proceedings of ISES solar world congress, Adelaide, Australia, pp 545-550
- [5] G.L. Morrison (2004), 'Water-in-glass evacuated tube solar water heaters', Solar Energy Vol. 76, pp 135-140.
- [6] L.J. Shah (2004), 'Vertical evacuated tubular-collectors utilizing solar radiation from all directions', Applied Energy Vol. 78, pp 371-395.
- [7] G.L. Morrison (2005), 'Measurement and simulation of flow rate in a water-in-glass evacuated tube solar water heater', Solar Energy Vol. 78, pp 257-267.
- [8] Indra Budihardjo (2007), 'Natural convection flow through Water-in-glass evacuated tube solar collectors', Solar Energy Vol. 81, pp 1460-1472.
- [9] Louise Jivan Shah (2007), 'Theoretical flow investigations of an all glass evacuated tubular collector', Solar Energy Vol. 81, pp 822-828.
- [10] Yong Kim (2007), 'Thermal performance comparisons of the glass evacuated tube solar collector with shapes of absorber tube', Renewable Energy Vol. 32, pp 772-795.
- [11] X.R. Zhang(2008), 'An Experimental study on evacuated tube solar collector using supercritical CO<sub>2</sub>', Applied Thermal Engineering Vol. 28, pp 1225-1233
- [12] I. Budihardjo (2009), 'Performance of Water-in-glass evacuated tube solar water heaters', Solar Energy Vol. 83, pp 49-56.
- [13] Liangdong Ma (2010), 'Thermal performance analysis of the glass evacuated tube solar collector with U-tube', Building and Environment Vol. 45, pp 1959-1967.