

# On The Comparison of Fuzzy Logic and State Space Averaging based Sliding Control Methods Applied on an Arc Welding Machine

Ires Iskender, and Ahmet Karaarslan

**Abstract**—In this study, the performance of a high-frequency arc welding machine including a two-switch inverter is analyzed. The control of the system is achieved using two different control techniques i- fuzzy logic control (FLC) ii- state space averaging based sliding control. Fuzzy logic control does not need accurate mathematical model of a plant and can be used in nonlinear applications. The second method needs the mathematical model of the system. In this method the state space equations of the system are derived for two different “on” and “off” states of the switches. The derived state equations are combined with the sliding control rule considering the duty-cycle of the converter. The performance of the system is analyzed by simulating the system using SIMULINK tool box of MATLAB. The simulation results show that fuzzy logic controller is more robust and less sensitive to parameter variations.

**Keywords**— Fuzzy logic, arc welding, sliding state space control, PWM, current control.

## I. INTRODUCTION

THE performance of welding machines and their circuit configurations vary with development of high-frequency power semiconductor devices. Operating the converters of the arc machines at high frequency increases the control performance of the systems. In arc welding, the main problem of concern during the control design is complexity and strong uncertainty. Reliable models that could relate process control input and output weld properties are not very well known [1]. Modern electronic welders are required to feature lightness, safety, reliability, cheapness and flexibility of operation. According to the developments of power electronics technology, new circuit topologies and control strategies are possible to achieve higher quality in this area [2]. The load current is controlled using fuzzy logic control and state-space averaging based sliding mode control methods.

Fuzzy logic control is a powerful method for controlling nonlinear systems. During the early seventies fuzzy logic was introduced as a way of formally describing and manipulating

linguistic information. This method defines the linguistic rules of a fuzzy logic controller, starting from a desired closed loop behavior and a plant model, both described via linguistic statements. It does not require solving the system mathematically, just needs relations between the variables of the plant in linguistic form [3].

The advantage of sliding mode controller is their switching control actions, which are appropriate to the on-off behavior of power switches. Ideally, the switching of control occurs at infinitely high frequency. In practice, the frequency can not be infinitely high due to the finite switching time and the undesired parasitic effects causing undesired chattering of the control. Infinitely high frequency is the main obstacle of sliding mode controllers and in this study, it is surmounted by applying a constant switching frequency using state space averaging technique. For controlling the load current, the phase-shift pulse-width modulation (PSPWM) technique method is used, whereby; the load current is controlled by varying the phase shift angle or the duty-cycle of the switches. Fuzzy logic control method and the slide state space averaging control are described and used to control the load current. Simulation results are given for different operating conditions and it is shown that both control methods eliminate the 100 Hz ripple of the load current and keep it constant at the preset value. The comparing of the results corresponding to two different control methods shows that the FLC is more robust and less sensitive to parameter variations.

## II. SYSTEM DESCRIPTION

The main system of the arc welding machine is shown in Fig. 1. The system consists of an uncontrolled rectifier, a two-switch single-phase inverter, a step-down high-frequency transformer, a mid-point rectifier, a filtering inductor and the load.

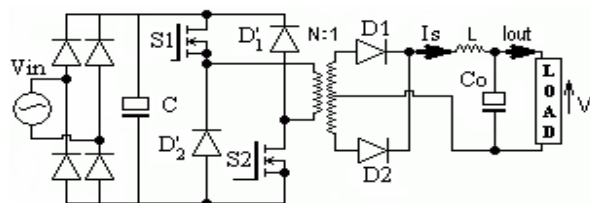

Fig. 1 Main system of arc welding machine

Manuscript received October 28, 2005. Many thanks to the scientific research unit of Gazi University for their supports in preparing the conditions and materials needed to do the theoretical and practical investigations.

Ires Iskender is with the Electrical Electronics Engineering Department, University of Gazi, Ankara, Maltepe Turkey (phone: 90-312-2317400-2315; fax: 90-312-2308434; e-mail: iredis@gazi.edu.tr).

Ahmet Karaarslan is with the Faculty of Industrial Arts Education, Computer Education Department, University of Gazi, Ankara, Besevler, Turkey (phone: 90-312-2126767-410; fax: 90-312-2127763; e-mail: akaraarslan@gazi.edu.tr).

The first stage is an uncontrolled rectifier connected to ac mains of  $220V_{rms}$  and 50 Hz. There is a filter capacitor connected at the output of the rectifier to decrease the peak-to-peak ripple of the dc-link voltage. The second stage is a two-switch single-phase inverter that converts dc-link voltage into a high frequency (40 kHz) square waveform ac signal. The third stage of the system is a high-frequency step-down transformer. The primary and secondary windings of the transformer are connected to the inverter and the mid-point rectifier, respectively. The purpose is to adjust the load current at the set value by varying the phase-shift angle or the duty-cycle of the inverter based on fuzzy logic control and state-space averaging based sliding mode control methods.

### III. MATHEMATICAL MODEL

The switching operation of the inverter in PSPWM method used in this study is shown in Table I. In this method, the inverter operation is divided into 3 modes depending on the “on” and “off” states of the semiconductor switches as shown in Fig. 2.

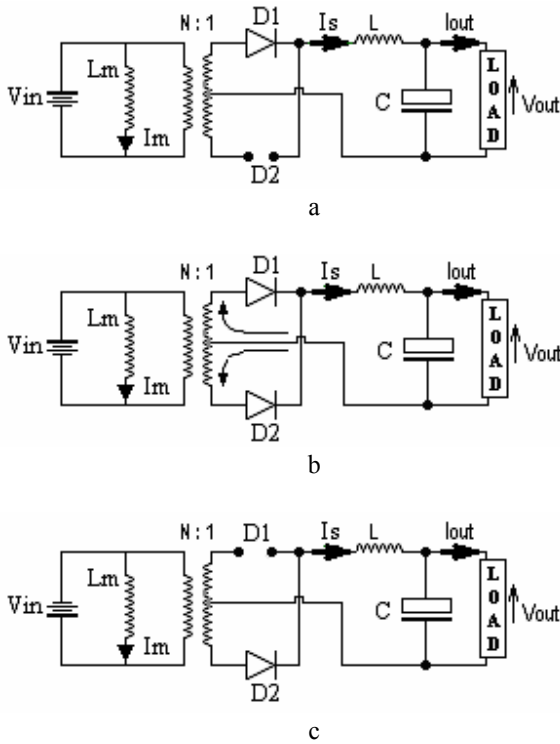

Fig. 2 Different operating modes of the converter  
 a) S1: on, S2: on b) S1: on, S2: off c) S1: off, S2: off

TABLE I  
 OPERATING MODES

MODES	ON	OFF
Mode 1	S1, S2	-
Mode 2	S1	S2
Mode 3	-	S1, S2

Mode1- Both switches (S1 & S2) are in ON state and the diodes are reverse-biased. The energy is charged in the magnetizing inductance and transferred to secondary windings of transformer. D1 is forward and the D2 is reverse biased.

Mode2- In this mode of operation, S1 is conducting and S2 is in OFF state and the current links through S1 and D1. In this duration the energy stored in the magnetic field is constant. The load current is equally shared between the mid-point rectifier diodes.

Mode3- Both switches (S1 & S2) are in OFF state. The voltage across the primary winding becomes negative generating a decreasing linear magnetizing current. In this period the magnetic energy is discharging. D2 is forward and D1 is reverse biased.

The difference between the welding converter topology proposed in this study and the conventional one is to insert an energy storage time of  $(1-D-K)T$ . By this method the stability and dynamic response of the system can be much improved when compared with the conventional welding converter [4]. Fig. 3 shows the time sequence of gate drive signal waveforms of switches S1, S2 and the transformer magnetizing current,  $I_m$ .

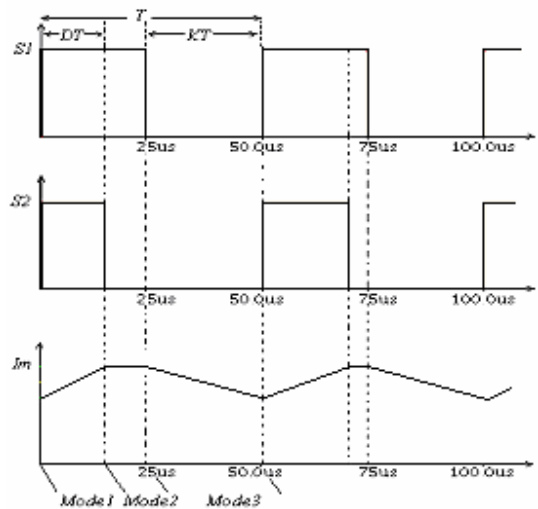

Fig. 3 PWM phase- shift control strategy and magnetizing current waveform

In Fig. 3, T and D are switching period and the duty cycle of the welding inverter, respectively. The state space equations of the system for the case where the switches are in ON state are as:

$$\left. \begin{aligned} \frac{dI_m}{dt} &= \frac{V_m}{L_m} \\ \frac{dI_0}{dt} &= \frac{I_m N - I_0}{RC} \end{aligned} \right\} 0 < t < DT \text{ S}_1: \text{ON}, \text{ S}_2: \text{ON} \quad (1)$$

The state equations corresponding to the case where S1 is ON and S2 is OFF are obtained as follows,

$$\left. \begin{aligned} \frac{dI_m}{dt} &= 0 \\ \frac{dI_0}{dt} &= \frac{I_m N - I_0}{RC} \end{aligned} \right\} DT \ll t \ll (1-K)TS_1: \text{ON}, S_2: \text{OFF} \quad (2)$$

The state equations corresponding to case where both switches are in off state are as follows,

$$\left. \begin{aligned} \frac{dI_m}{dt} &= -\frac{V_{in}}{L_m} \\ \frac{dI_0}{dt} &= \frac{I_m N - I_0}{RC} \end{aligned} \right\} DT \ll t < T \quad S_1: \text{OFF}, S_2: \text{OFF} \quad (3)$$

In Eqn. 4 the moving averages of  $I_m$  and  $I_0$  are shown by  $X_1$  and  $X_2$ , respectively.

$$I_m = X_1, \quad I_0 = X_2 \quad (4)$$

$$\frac{dI_m}{dt} = \dot{X}_1, \quad \frac{dI_0}{dt} = \dot{X}_2 \quad (5)$$

State space averaged equations can be obtained by combining equations 1, 2, 3 considering equations 4, 5 and the duty-cycle of the converter,  $D$  as;

$$\dot{X}_1 = \frac{V_{in}}{L_m} [D - K] \quad (6)$$

$$\dot{X}_2 = \frac{1}{RC} [X_1 N - X_2] \quad (7)$$

**A. Fuzzy Logic Control Method**

Fuzzy logic can be applied to control, modeling and estimation of the power electronics systems. In general fuzzy expert system is applicable wherever the knowledge base of expert system contains fuzziness.

A FLC essentially embeds experience of a human operator, and sometimes those of a designer. The conventional control method is normally based on mathematical model of a plant. Often, the plant model is unknown or ill-defined. Even if the plant model is known, there may be a parameter variation problem.

Fig. 4 shows the block diagram of the FLC that control the current of a welding machine. The output current is compared with the reference signal to give the current error. The comparison of two consequent current errors gives the derivative error. The current error and derivative of error are fed to the controller.

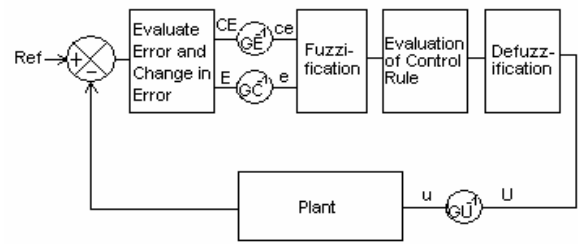

Fig. 4 Basic structure of the fuzzy controlled system

Two main functions of the blocks are i-fuzzification and ii-defuzzification. Fuzzification of the input variables (error and derivative of the error) is the first step of FLC and this is done by using membership function of the error and change in error of output of the plant (here, load current). Fuzzification is performed by establishing the variation intervals of the variables (division of each variable into segments) and defining a number of membership functions inside such intervals.

The overall performance of the system is affected by the shapes and number of the membership functions that are chosen according to the experience of expert people about the process.

The rules that should be activated for a specific input signal condition is determined by fuzzy controller using the fuzzy rule base (Table I) and then the effective control action is obtained using the composition operation such as MAX-MIN method [5]. The set of rules for fuzzy compensation is given in the matrix form in Table I where all symbols are abbreviations defined as:

- NB : Negative Big
- NM : Negative Medium
- NS : Negative Small
- NVS: Neg. Very Small
- Z : Zero
- PB : Positive Big
- PM : Positive Medium
- PS : Positive Small
- PVS : Positive Very Small

TABLE II  
RULE BASE TABLE FOR LOAD CURRENT CONTROLLER

CE	NB	NM	NS	Z	PS	PM	PB
E	PVB	PVB	PB	PM	PS	PVS	NC
NB	PVB	PB	PM	PS	PVS	NC	NVS
NM	PB	PM	PS	PVS	NC	NVS	NS
NS	PM	PS	PVS	NC	NV S	NS	NM
Z	PM	PS	PVS	NC	NV S	NS	NM
PS	PS	PVS	NC	NV S	NS	NM	NB
PM	PVS	NC	NV S	NS	NM	NB	NVB
PB	NC	NV S	NS	NM	NB	NVB	NVB

The variables used for fuzzification are  $E(k)$  and  $CE(k)$ ,

$$E(k) = I_{ref} - I(k) \quad \text{and} \\ CE(k) = E(k) - E(k-1)$$

Where  $E(k)$  is loop error,  $CE(k)$  is change in loop error,  $k$  is sampling interval,  $I_{ref}$  is the reference current value, and  $I(k)$  is the load current

In the simulation, per unit value of  $E(k)$  is used i.e. it is scaled by  $I_{ref}$  ( $E(k) / I_{ref}$ ). In this study, error of the load current ( $E$ ), derivative of the load current error ( $CE$ ) and the phase-shift angle are considered as fuzzy variables, with possible values given by fuzzy sets such as Positive Medium, Positive Small, Zero and so on.

The membership function plots of the variables  $E$  (load current error),  $CE$  (derivative error or rate of change of error) are shown in Fig. 5 and the membership function of phase-shift angle is shown in Fig 6. The sensitivity of a variable determines the number of fuzzy subsets, respectively. It is evident that for any input data  $E$  (error) and  $CE$  (derivative error), only four rules will be valid in the entire rule base given in Table I.

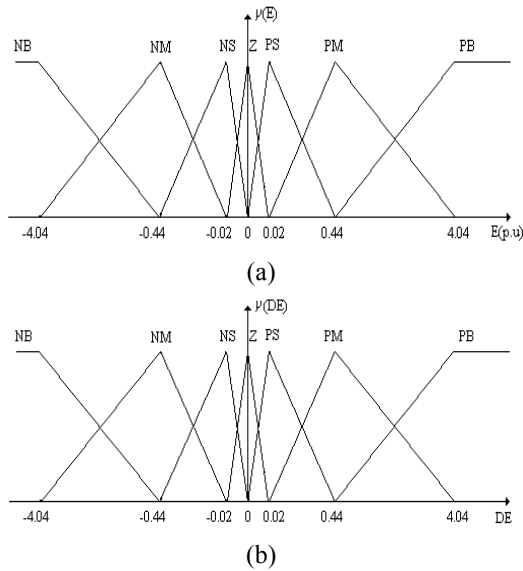

Fig. 5 Membership functions for (a) Load current error (b) Load current derivative error

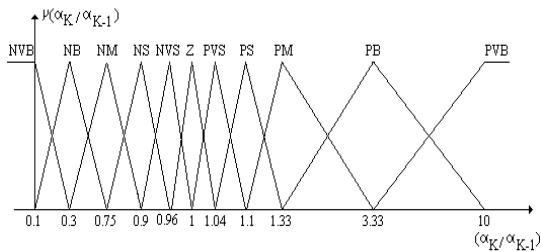

Fig. 6 Membership functions for Phase-shift angle ( $\alpha_k/\alpha_{k-1}$ )

In defuzzification, the output of the fuzzy controller (a fuzzy set) is converted to a crisp value required by the plant. This process can be performed by several methods, of the most common ones being the center of gravity (centroid) and height methods. In this study, the height method has been used due to its simplicity and quickness in comparison with the centroid method.

**B. State Space Averaging based Sliding Control**

In this study the moving average of the load current is used. This will significantly simplify the design.  $X_2$  is the moving average of the output current, and  $R$  is the desired output current. The sliding surface in the state space is given by  $X_2 = R$ . The following conditions can be written according to the sliding-mode control rules given in [6].

$$\dot{X}_2 < 0 \text{ if } X_2 > R \tag{8}$$

$$\dot{X}_2 > 0 \text{ if } X_2 < R \tag{9}$$

A first order path can be selected based on the following equation and the convergence speed is controlled according to the Eqn. 10.

$$\dot{X}_2 = -\lambda(X_2 - V_{ref}) \tag{10}$$

$\lambda$  is a positive real number and is called the convergence factor. (Fig. 7)

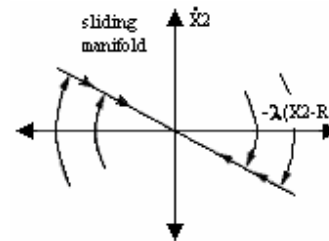

Fig. 7 Convergence relation for control of arc welding

Based on Eqn. 10, the larger the convergence factor the faster the system will reach its steady state. However, due to limits on the system parameters such as duty cycle, it is not possible to increase the convergence factor beyond a certain value [5]. Duty cycle can not be greater than %50 of the switching period.

The control parameter of this technique can be obtained by combining Eqns. 6, 7 and 10.

$$D = \frac{L_m}{V_{in}} \left[ -\frac{\lambda(X_2 - I_{ref})}{N} (1 - \lambda RC) + \frac{V_{in}}{L_m} K \right] \tag{11}$$

The controller given in Eqn. 11 is a function of time and does not depend on the state variables. The controller regulates the welding output current by means of duty cycle. Sliding average control strategy eliminates the main disadvantage of sliding mode control being variable switching frequency.

**IV. THE SIMULATION OF THE SYSTEM**

For verifying the control strategies discussed above, the system was simulated using fuzzy control method for two different cases as: i-  $L$  (load inductance) = 200  $\mu$ H and ii-  $L$  = 75  $\mu$ H. The FLC simulation results are compared with those obtained using state space averaging based sliding technique.

The dc-link capacitor of the system used in simulation has an initial arbitrary voltage of 140 V and the converter is connected to ac mains of 220 V and 50 Hz. The values of dc-link and load capacitors are 2 mF and 20  $\mu$ F, respectively. The load is considered as a resistor with resistance value of 0.2  $\Omega$  and the sampling time interval is 100  $\mu$ s.

Fig. 8 shows the dc-link voltage and the load current for the case where the phase-shift angle is zero and the system is free of control. It is shown that the dc-link voltage and load current have a ripple with 100 Hz frequency. The load current amplitude value is about 100 A.

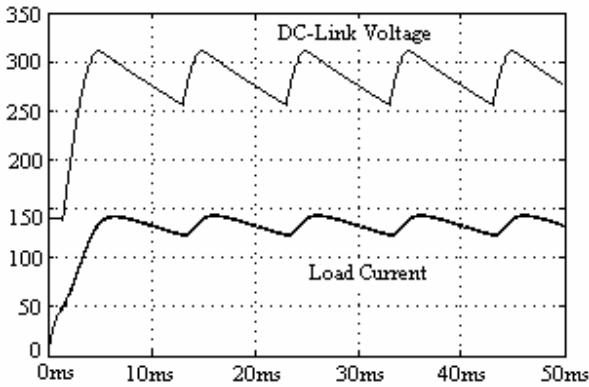

Fig. 8 DC-link voltage and the load current (Phase-shift angle is zero)

Fig. 9-a and 9-b show dc-link voltage, load current and the phase-shift angle of the converter corresponding to applications of FLC and PI methods. The reference current is 80 A and it is changed to 110 A at the instant of 20 ms. Both methods were tuned for this operating condition. In both methods the phase-shift angle changes in such a way to keep the load current constant satisfactorily at the set levels.

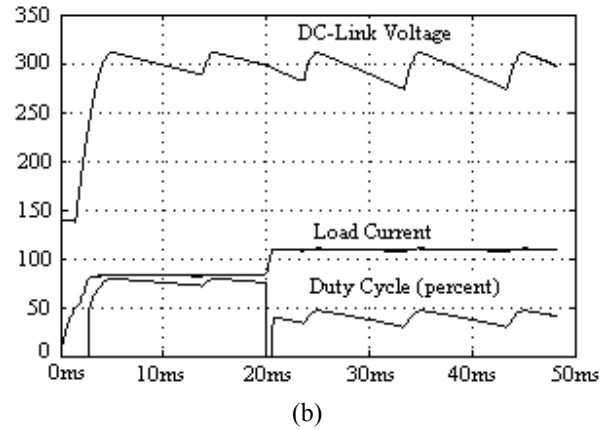
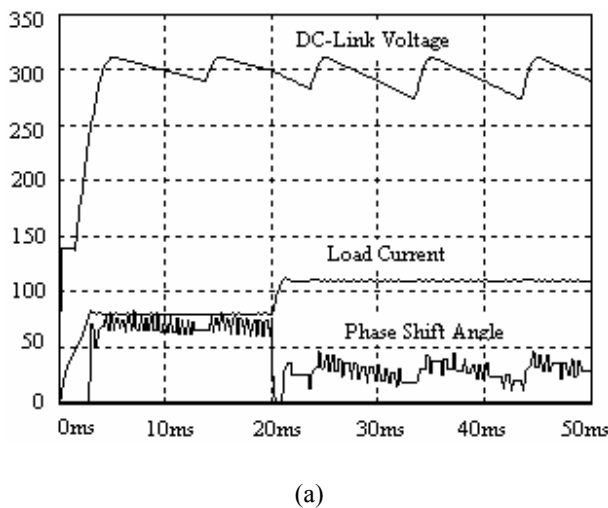
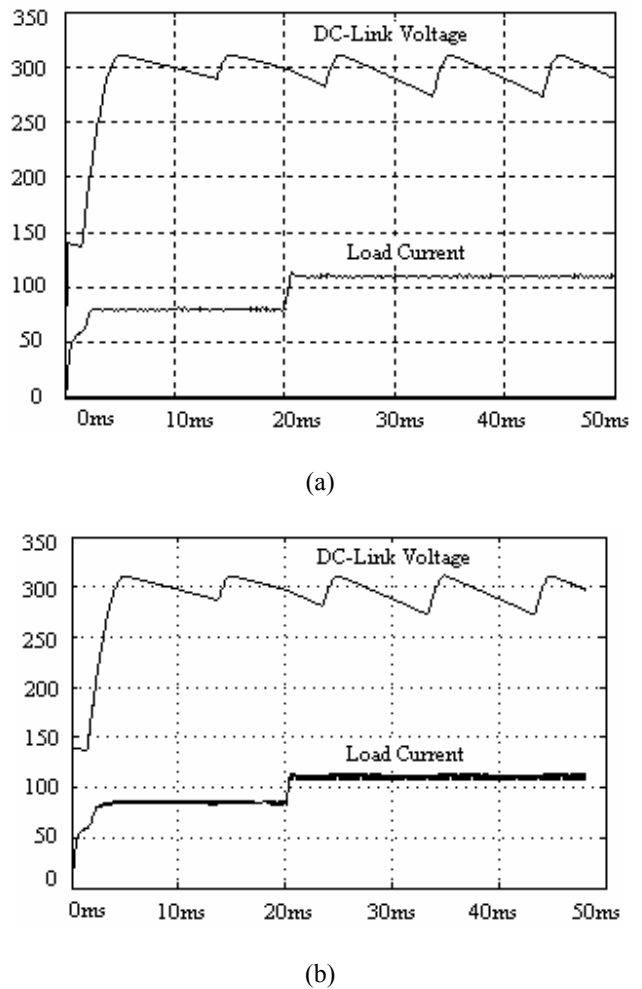

Fig. 9 DC-link voltage, phase-shift angle and load current a) using FLC b) using sliding mode control

It is shown that the state space averaging based sliding controller is more sensitive to changes of the system parameters with respect to FLC.



(a)



(a)

(b)

Fig. 10 DC-link voltage and load current for filter inductance of 75  $\mu$ H a) by FLC b) by Sliding

## V. CONCLUSION

The system was modeled and simulated in MATLAB/SIMULINK. The load of the system was considered to be linear and resistive. While the fuzzy logic control does not need accurate mathematical model of a plant, the second method needs the mathematical model of the system. The simulation results were given for different operating conditions and it was found that both methods were success in eliminating the 100 Hz ripple of the load current and keeping the load current constant at the preset value. The comparing of the results corresponding to two different control methods shows that the FLC is more robust and less sensitive to parameter variations. The experimental work of this study is under progress.

## REFERENCES

- [1] "Sliding Mode Control of a Heat Equation with application to Arc Welding", Sergey Drakunov, Enrique Barbieri and David A. Silver Department of Electrical Engineering and Computer Science Tulane University New Orleans, USA, IEEE September 15-18, 1996.
- [2] L. Malesani, P. Mattavelli, L. Rossetto, P. Tenti, W. Marin, A. Pollmann "Electronic Welder with High-Frequency Resonant Inverter" IEEE Trans. on Industry App., vol. 31, No. 2, March/April 1995.
- [3] Paolo Mattavelli "General-Purpose Fuzzy Controller for dc-dc Converters" IEEE Transactions on PE, vol, 12, No, 1, January 1997.
- [4] Hiroto Terashi, Isaac Cohen and Tamotsu Ninomiya "Stability and Dynamic Response Improvement of Flyback DC-DC Converter by a Novel Control Scheme" IEEE 0-7803-7404-5/02, 2002, pp. 389-394.
- [5] R. Lowen, M. Roubens "Fuzzy Logic State of the Art", Kluwer Academic Press, Amesterdam, 1993.
- [6] J. Mahdavi, A. Emadi, H.A. Toliyat, Aplication of State Space Averaging Method to Sliding Mode Control of PWM DC/DC Converters, IEEE Industry Applications Society, Annual Meeting, October, 1997.



**Ires Iskender** graduated from Gazi University, Faculty of Engineering and Architecture, Department of Electrical and Electronics Engineering in 1989 in Ankara, Turkey. He received his MS and Ph degrees from Middle East Technical University, Engineering Faculty, Electrical and Electronics Engineering Department in Ankara, in 1990 and 1996, respectively. Currently he is instructor in Gazi

University and gives Power Electronics and Electrical machine courses in this university.



**Ahmet Karaarslan** was born in Afyon/Turkey in 1981. He graduated from Gazi University, Faculty of Engineering and Architecture Department of Electrical and Electronics Engineering in 2002 in Ankara, Turkey. He received his Master of Science Degree from Gazi University Institute of Science and Technology Department of Electrical and Electronics Engineering in 2005 in Ankara. He is educating his

Ph.D. Program at the same Institute.

He is a research assistant in the Faculty of Industrial Arts Education, Department of Computer Education.